

SA000694

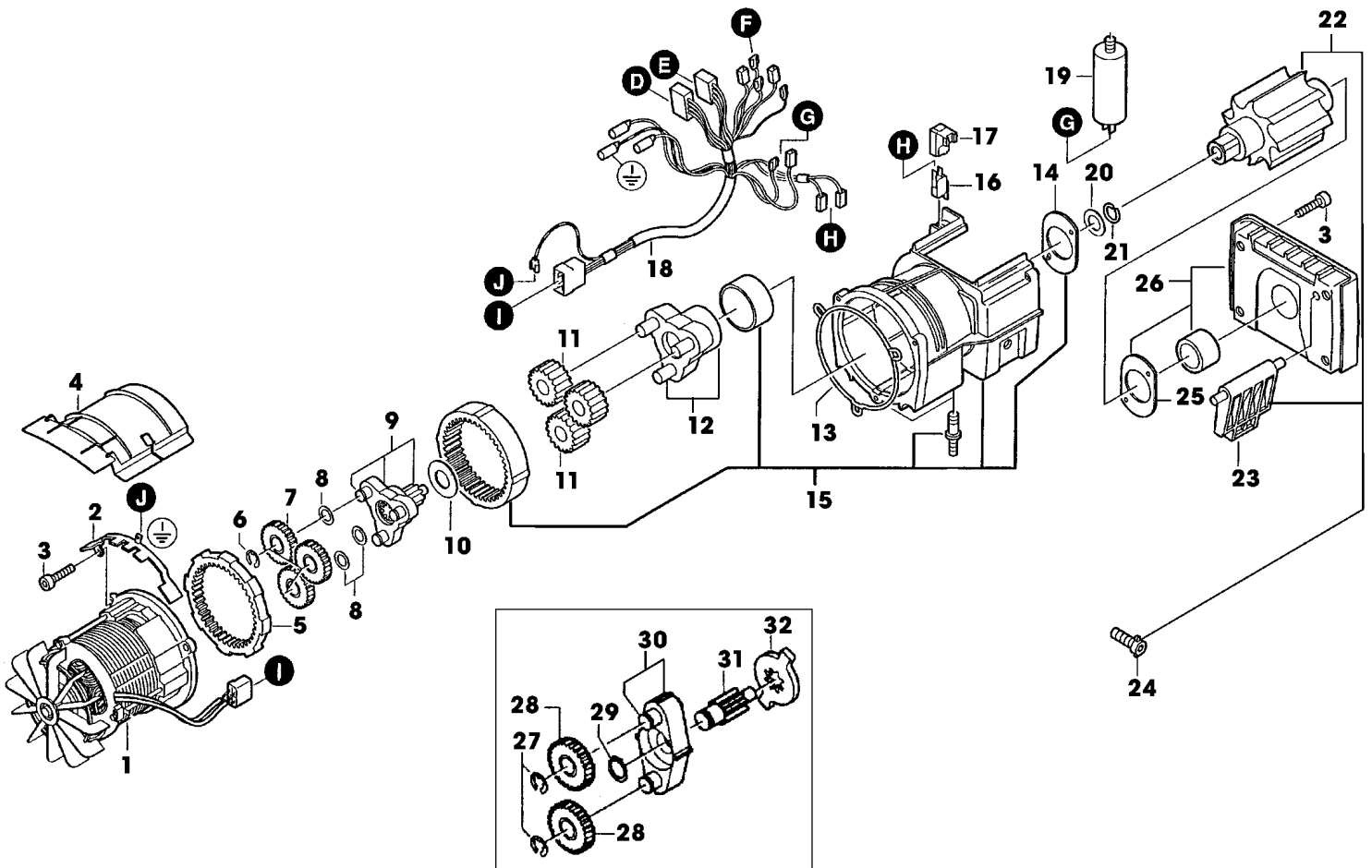

TEIL	STCK.NR	BEZEICHNUNG	STCK.	SER-NR.-	-SER-NR.	BEMERKUNG
1	SA35107	DECKEL	1			
2	SA35108	EINSATZ	1			
3	SA35983	SCHALTER	1			ASSY
4	SA35986	KNOPF	1			
5	SA35984	SCHALTUNGSPLATTE	1			
6	SA35989	SCHRAUBE	2			4X12
7	SA35988	SCHRAUBE	2			
8	SA35101	SCHRAUBE	20			KB 40X25/16
9	SA35987	DECKEL	1			
10	SA35983	SCHALTER	1			(SUB FOR SA35985)
11	SA35112	SCHALTER	1			
12	SA35099	GEHAEUSE	1			UP
13	SA35109	STECKER	1			
14	SA35132	KABELBAUM	1			
15	SA35100	GEHAEUSE	1			LOW
16	SA35105	FEDERKLEMME	1			
17	SA35104	STELLSCHRAUBE	1			
18	SA35103	KNOPF	1			



SA000697



TEIL	STCK.NR	BEZEICHNUNG	STCK.	SER-NR.-	-SER-NR.	BEMERKUNG
1	SA35117	ELEKTROMOTOR	1			2200W
2	SA35118	BLECH	1			
3	SA35119	SCHRAUBE	7			
4	SA35120	PLATTE	1			
5	SA35121	ZAHNKRANZ, INNENVERZAHNT	1			
6	SA35122	FEDERRING	3			12
7	SA35123	ZAHNRAD	3			
8	SA35124	ANTRIEBSSCHEIBE	3			
9	SA35125	PLANETENRADTRAEGER	1			ORD KEYS 27,28,29,30,31,32
10	SA35126	ANTRIEBSSCHEIBE	1			
11	SA35128	ZAHNRAD	3			
12	SA35305	PLANETENRADTRAEGER	1			
13	SA35134	DICHTUNG	1			
14	SA35143	ABSTREIFER	1			
15	SA35303	UEBERSETZUNGSGEHAEUSE	1			
16	SA35136	SCHALTER	1			
17	SA35137	FUEHRUNG	1			
18	SA35132	KABELBAUM	1			
19	SA31860	KONDENSATOR	1			(SUB FOR SA35133)
20	SA35139	ANTRIEBSSCHEIBE	1			
21	SA35324	SPRENGRING	1			10
22	SA35304	SCHNEIDWERK	1			ASSY
23	SA35141	PLATTE	1			
24	SA35104	STELLSCHRAUBE	1			
25	SA35143	ABSTREIFER	1			
26	SA35144	LAGERFLANSCH	1			
27	SA35122	FEDERRING	2			12 (SUB FOR SA35125)
28	SA35123	ZAHNRAD	2			(SUB FOR SA35125)
29	SA36447	ANTRIEBSSCHEIBE	1			(SUB FOR SA35125)
30	SA36446	PLANETENRADTRAEGER	1			(SUB FOR SA35125)
31	SA36450	ZAHNRAD	1			(SUB FOR SA35125)
32	SA36448	MITNEHMER	1			(SUB FOR SA35125)

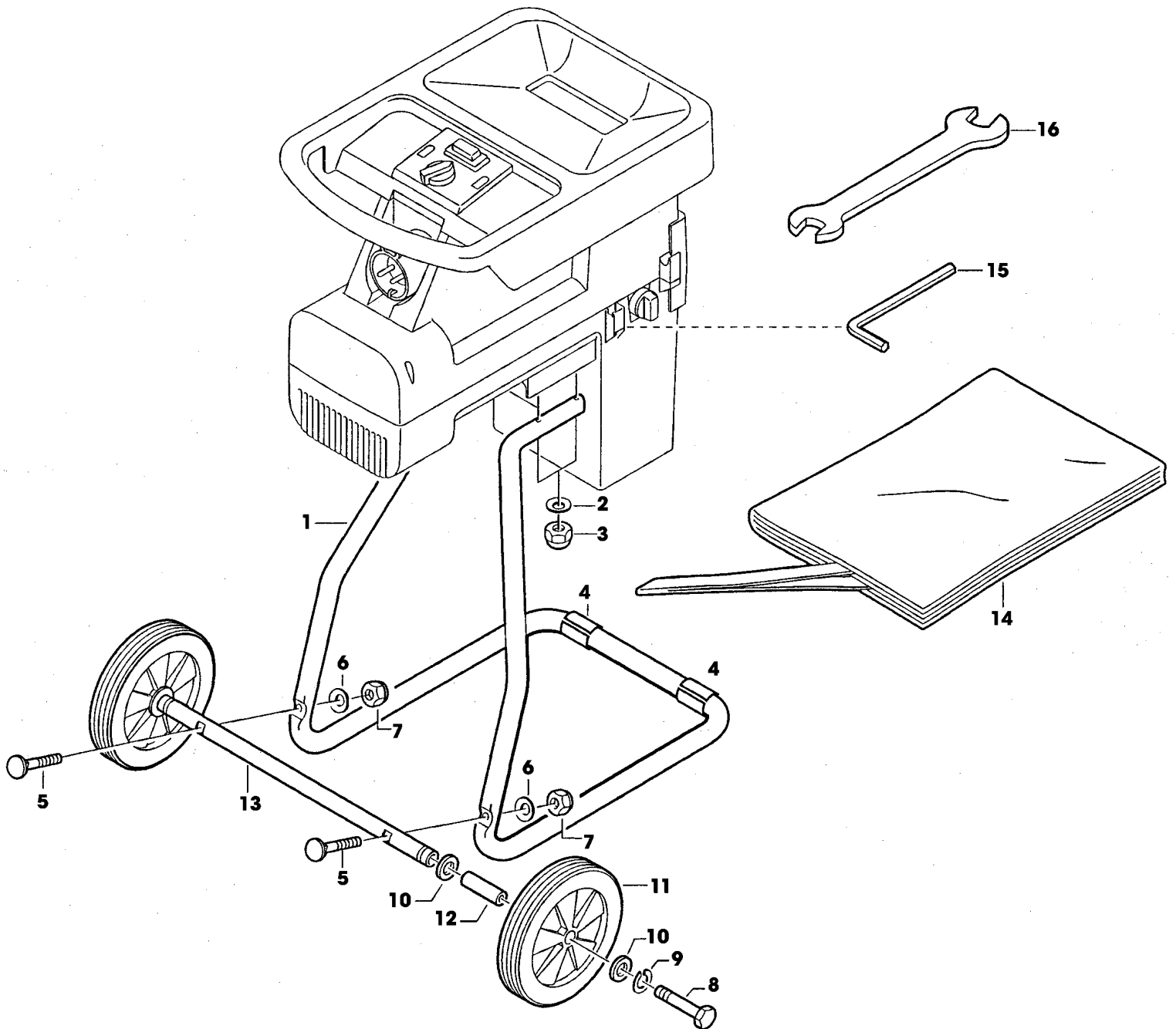

SA000701



TEIL	STCK.NR	BEZEICHNUNG	STCK.	SER-NR.-	-SER-NR.	BEMERKUNG
1	SA35306	RAHMEN	1			
2	SA11243	UNTERLEGSCHIEBE	4			(SUB FOR SA35149)
3	SA35237	SICHERUNGSMUTTER	4			M6
4	SA35151	MONTAGEBANDTEILE	2			
5	SA16327	SCHRAUBE	2			M6X50
6	SA11243	UNTERLEGSCHIEBE	2			(SUB FOR SA35149)
7	SA11244	SICHERUNGSMUTTER	2			(A) M6
8	SA15385	SECHSKANTSCHRAUBE	2			M8X55
9	SA15233	FEDERRING	2			A8
10	SA15213	UNTERLEGSCHIEBE	4			(A) A8,4
11	SA13943	RAD KPL. MIT BEREIFUNG	2			
12	SA35084	HUELSE	2			
13	SA35085	ACHSE	1			
14	SA35152	HACKSCHNITZEL-FANGBEHAELT	1			
15	SA16196	INNEN-6KT.SCHRAUBENDR.-SA	1			5K
16	SA18311	MAUL-RINGSCHLUESSEL	1			SW 10/13
	SA35187	LEISTE	2			
		(A) WERDEN NUR NOCH IN PACKMENGEN GELIEFERT				

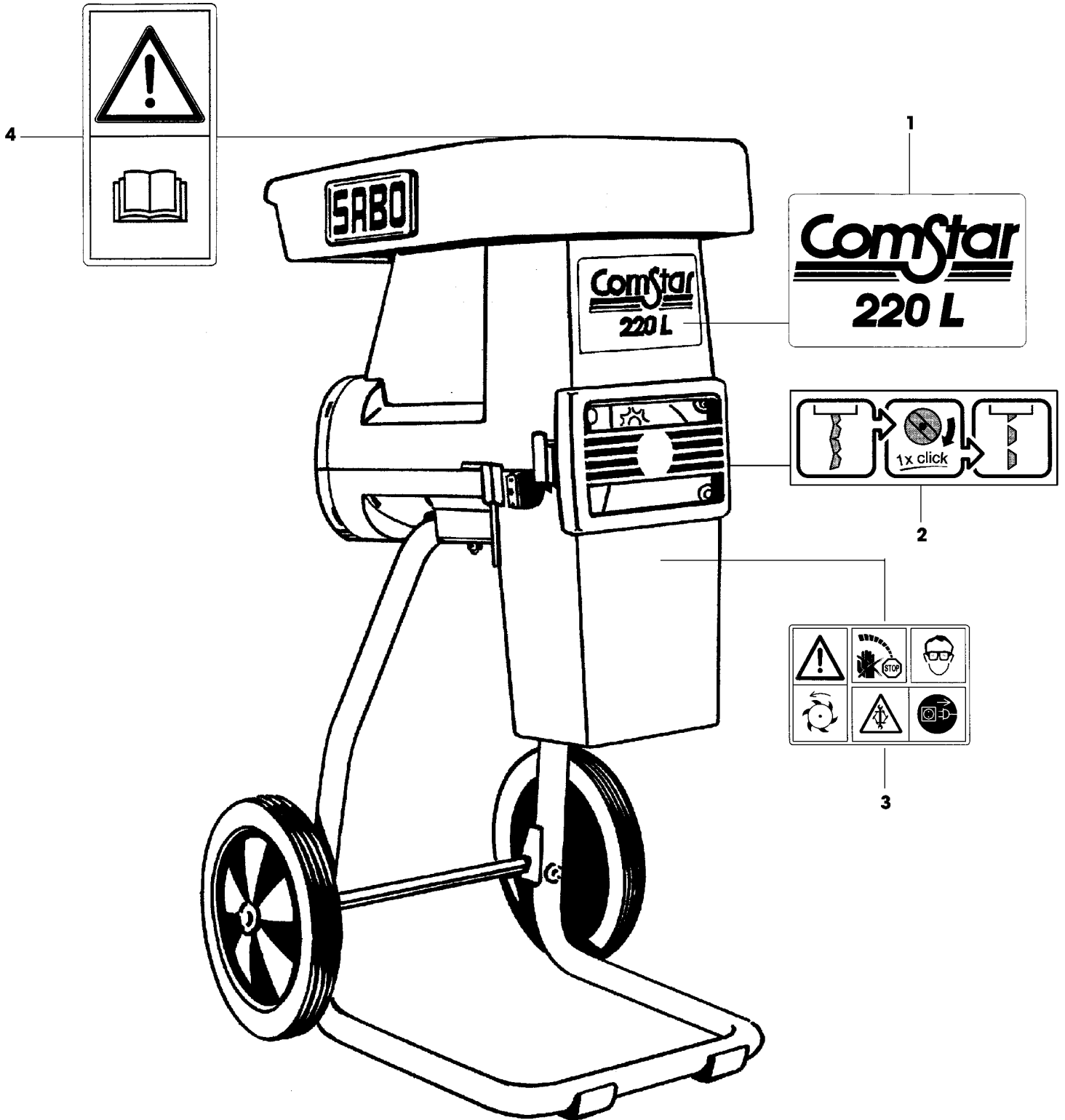

SA000704



TEIL	STCK.NR	BEZEICHNUNG	STCK.	SER-NR.-	-SER-NR.	BEMERKUNG
1	SA35081	AUFKLEBER	1			
2	SA35188	AUFKLEBER	1			
3	SA35083	AUFKLEBER	1			
4	SA35080	AUFKLEBER	1			