

SA001823

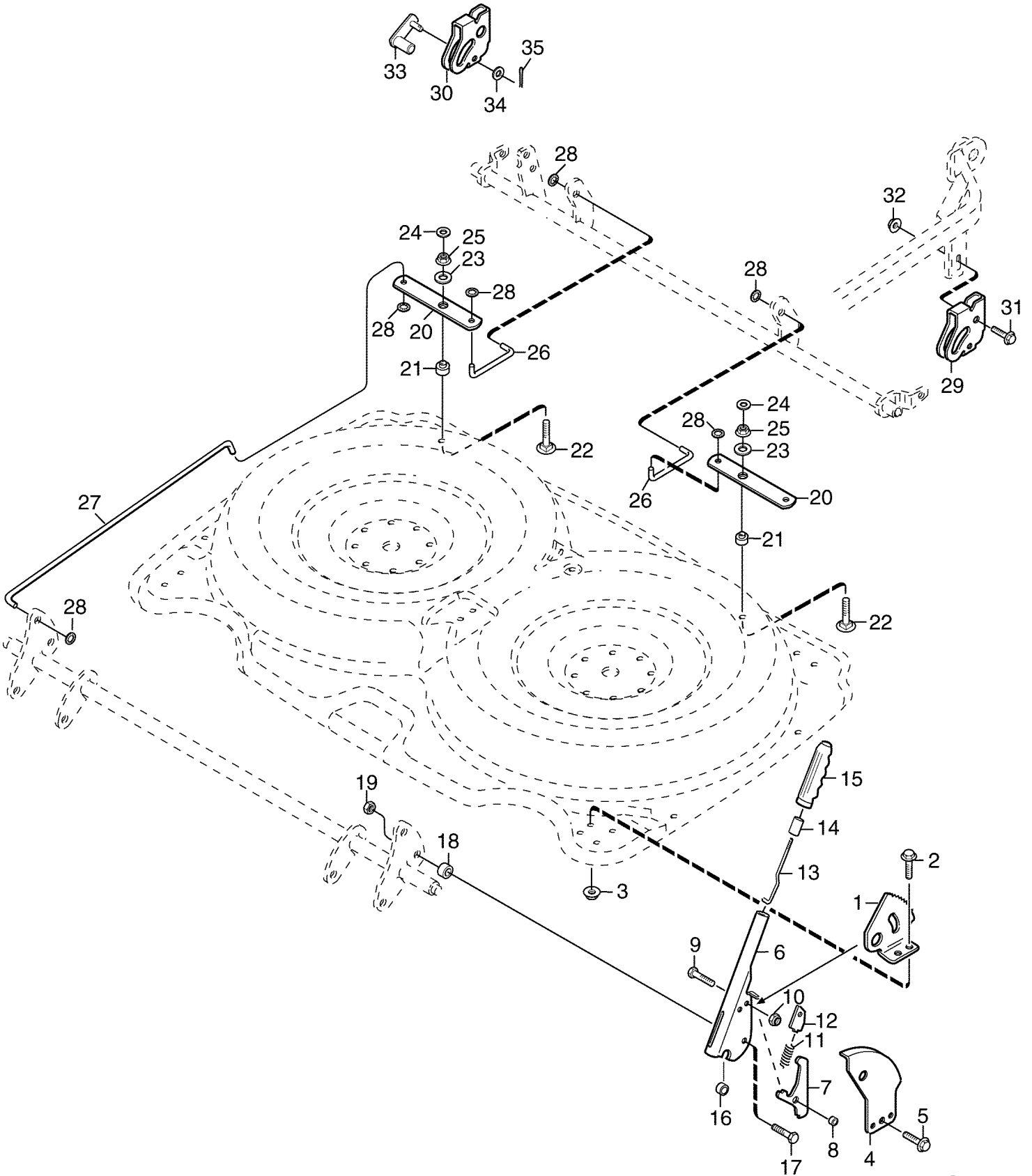

TEIL	STCK.NR	BEZEICHNUNG	STCK.	SER-NR.-	-SER-NR.	BEMERKUNG
1	SB1134518704	MAEHGEHAEUSE	1			
2	SB1134432301	RAHMEN	2			
3	03M7092	SCHRAUBE	4			M6X16
4	E63524	MUTTER	4			M6
5	SB1134432006	KONSOLE	1			
6	19M7866	SCHRAUBE	1			M8X20
7	E63525	MUTTER	1			M8
8	SB1134468802	FLASCHENZUG	1			ASSY, INCL KEYS 9, 10, 11, 12, 13, 14, 15
9	SB1134457401	FEDER	1			
10	SB1134457701	DREHHEBEL	1			
11	19M7163	SECHSKANTSCHRAUBE	1			M8X25
12	14M7327	SICHERUNGSMUTTER	1			M8
13	19M8008	SECHSKANTSCHRAUBE	1			M8X35
14	14M7327	SICHERUNGSMUTTER	1			M8
15	SB1134448101	MUTTER	2			
16	SB1134490501	KETTENSAEGEN-SCHWERT	1			
17	SB9838953012	SCHRAUBE	2			(SUB FOR SB9836953012)
18	SB1134489004	VORDERACHSE	1			FRONT
19	SB1134006800	LAGER	2			
20	SB1134429201	LAGERGEHAEUSE (OHNE LAGER	1			LH
21	SB1134429202	LAGERGEHAEUSE (OHNE LAGER	1			RH
22	19M7865	SCHRAUBE	4			M8X16
23	E63525	MUTTER	4			M8
24	SB1134428401	RAD	2			
25	SB1134431901	LAGER	4			
26	SB1134431801	ACHSE	2			
27	19M9093	SECHSKANTSCHRAUBE	2			M8X120
28	E63525	MUTTER	2			M8
29	SB1134487604	HINTERACHSE	1			REAR
30	SB1134006800	LAGER	2			
31	SB1134468901	STUETZE	2			
32	19M7775	SCHRAUBE	2			M6X16
33	14M7165	SICHERUNGSMUTTER	2			M6
34	SB1134429901	WINKEL	1			LH
35	SB1134429902	WINKEL	1			RH
36	19M7865	SCHRAUBE	4			M8X16
37	E63525	MUTTER	4			M8
38	SB1134343401	ROLLE	2			
39	SB1134004105	BUECHSE	2			
40	SB9897106012	SCHRAUBE	2			M10X60 8.8 (SUB FOR 03M7073)
41	CC19674	FLANSCHMUTTER	2			M10
42	SB1134454403	ARM	1			LH
43	SB1134454404	ARM	1			RH
44	SB1134131901	LAGER	4			
45	58M5632	SCHMIERNIPPEL	2			M6
46	19M7557	SECHSKANTSCHRAUBE	2			M10X16
47	24M7136	UNTERLEGSCHIEBE	2			10X26X2,0
48	24M7053	UNTERLEGSCHIEBE	2			17X30X3,0
49	SB1134474501	UNTERLEGSCHIEBE	2			



SA001824



TEIL	STCK.NR	BEZEICHNUNG	STCK.	SER-NR.-	-SER-NR.	BEMERKUNG
1	SB1134429001	SCHALTSEGMENT	1			
2	19M7865	SCHRAUBE	2			M8X16
3	E63525	MUTTER	2			M8
4	SB1134429103	RAHMEN	1			
5	SB9945081616	SCHRAUBE	1			M8X16
6	SB1134521501	HEBEL	1			ASSY, INCL KEYS 7, 8, 9, 10, 11, 12, 13 14, 15
7	SB1134301002	SCHALTSEGMENT	1			
8	SB1134511401	DISTANZSTUECK	1			
9	19M7077	SECHSKANTSCHRAUBE	1			M6X20
10	14M7165	SICHERUNGSMUTTER	1			M6
11	SB1134326201	DRUCKFEDER	1			
12	SB1134300901	SCHLUESSEL	1			
13	SB1134304101	STANGE	1			
14	SB1134305101	KNOPF	1			
15	SB9406000600	GRIFF	1			
16	SB1134242701	DISTANZSTUECK	1			
17	19M7922	SECHSKANTSCHRAUBE	1			M8X40
18	SB1134311303	DISTANZSTUECK	1			
19	14M7327	SICHERUNGSMUTTER	1			M8
20	SB1134429602	ARM	2			
21	SB1134429802	DISTANZSTUECK	2			
22	03M7119	SCHRAUBE	2			M8X50
23	24M7055	UNTERLEGSCHIEBE	2			8,4X16X1,5
24	24M7298	UNTERLEGSCHIEBE	2			8,4X24X2,0
25	14M7327	SICHERUNGSMUTTER	2			M8
26	SB1134489402	STANGE	2			
27	SB1134429402	STANGE	2			
28	SA34282	FEDERMUTTER	8			8,0
29	SB1134430403	PLATTE	1			LH
30	SB1134430404	PLATTE	1			RH
31	19M7865	SCHRAUBE	2			M8X16
32	E63525	MUTTER	2			M8
33	SB1134430701	SCHLIESSHAKEN	2			
34	24M7054	UNTERLEGSCHIEBE	2			6,4X12X1,5
35	11M7082	SPLINT	2			2,5X20

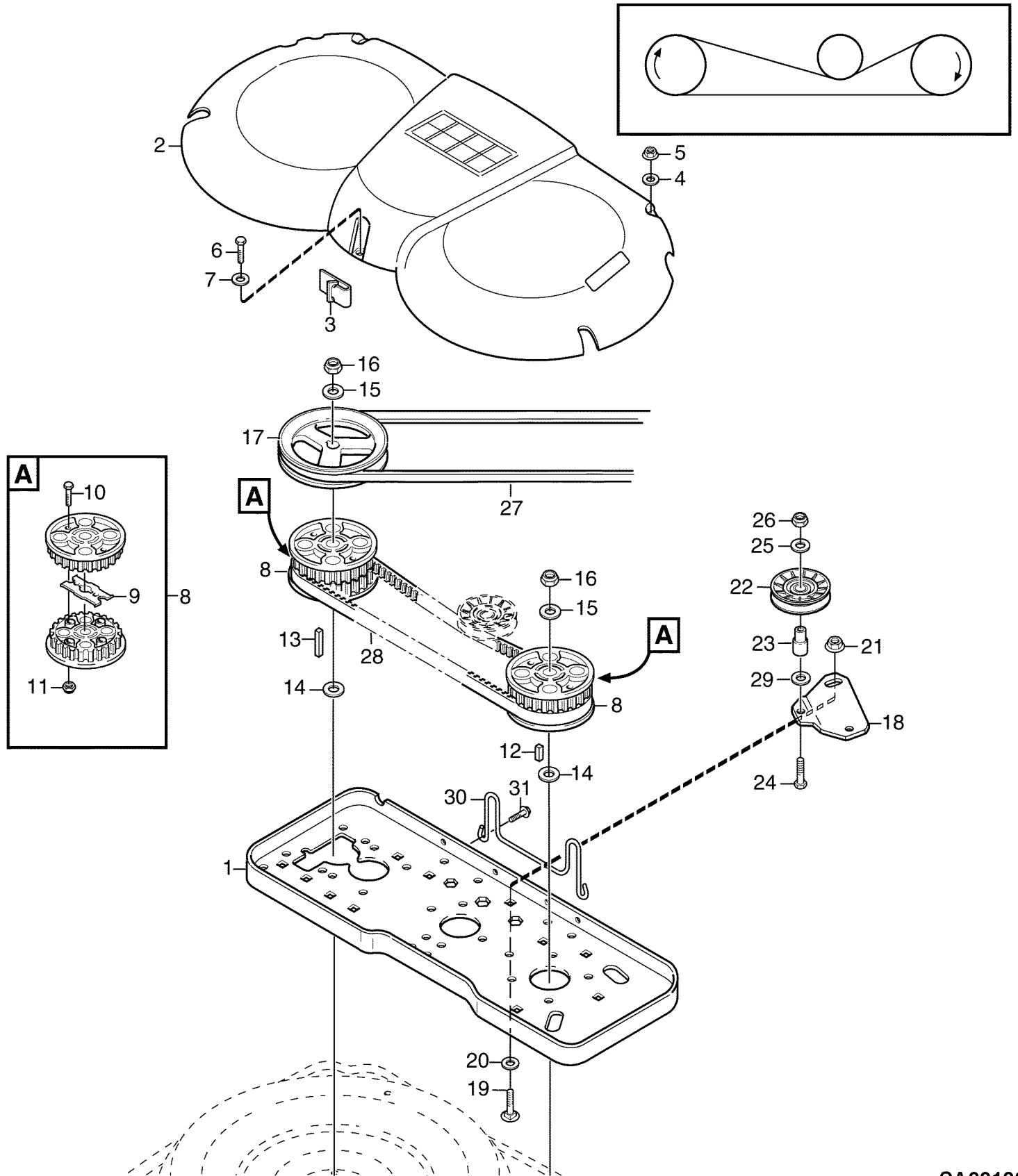

SA001825



TEIL	STCK.NR	BEZEICHNUNG	STCK.	SER-NR.-	-SER-NR.	BEMERKUNG
1	SB1134522901	PLATTE	1			
2	SB1134486502	DECKEL	1			
3	SB1134363201	FEDERKLEMME	3			
4	24M7055	UNTERLEGSCHLEIFE	2			8,4X16X1,5
5	14M7327	SICHERUNGSMUTTER	2			M8
6	SB9942061216	SCHRAUBE	1			M6X12
7	24M7139	UNTERLEGSCHLEIFE	1			6,4X18X2,0
8	SB1134367901	RIEMENSCHLEIFE	2			ASSY, INCL KEYS 9, 10, 11
9	SB1134359701	VERSTAERKUNG	1			
10	19M7286	SECHSKANTSCHRAUBE	2			M6X25
11	14M7165	SICHERUNGSMUTTER	2			M6
12	SB1134032301	SCHLUESSEL	1			LGTH = 25 MM
13	SB1134032304	SCHLUESSEL	1			LGTH = 45 MM
14	24M7053	UNTERLEGSCHLEIFE	2			17X30X3,0
15	24M7180	UNTERLEGSCHLEIFE	2			12,5X35X3,0
16	SB9712123102	SICHERUNGSMUTTER	2			M12
17	SB1134473201	RIEMENSCHLEIFE	1			
18	SB1134453701	ARM	1			
19	03M7093	SCHRAUBE	2			M8X25
20	24M7044	UNTERLEGSCHLEIFE	2			12X22X2,0
21	E63525	MUTTER	2			M8
22	SB1134305301	SPANNROLLE	1			
23	SB1134431603	WELLE	1			
24	19M7358	SECHSKANTSCHRAUBE	1			M10X40
25	24M7136	UNTERLEGSCHLEIFE	1			10X26X2,0
26	SB1134477501	SICHERUNGSMUTTER	1			
27	SB9585012701	KEILRIEMEN	1			
28	SB9585013301	STEUERRIEMEN	1			
29	24M7134	UNTERLEGSCHLEIFE	1			10,5X22X2,0
30	SB1134474701	FUEHRUNG	1			
31	SB9945081616	SCHRAUBE	2			M8X16

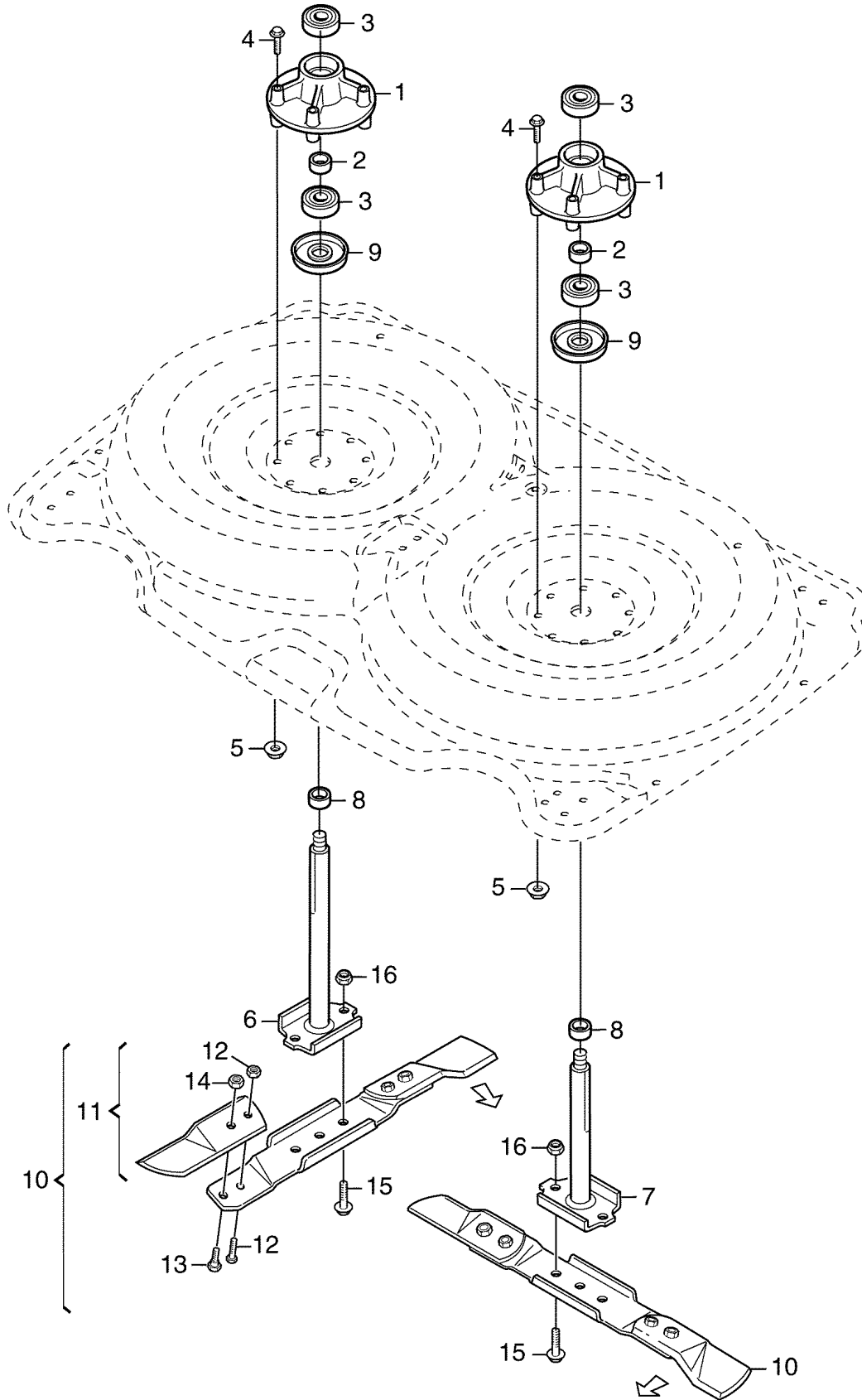

SA001826



TEIL	STCK.NR	BEZEICHNUNG	STCK.	SER-NR.-	-SER-NR.	BEMERKUNG
1	SB1134504901	GEHAEUSE	2			ASSY, INCL KEYS 2, 3
2	SB1134372504	DISTANZSTUECK	1			
3	SB9549002000	KUGELLAGER	2			
4	19M7270	SECHSKANTSCHRAUBE	8			M8X65
5	E63525	MUTTER	8			M8
6	SB1134505203	WELLE	1			
7	SB1134505204	WELLE	1			
8	SB1134372504	DISTANZSTUECK	2			
9	SB1134376801	STAUBSCHUTZ	2			
10	SB1134489601	MAEHMESSER	2			ASSY, INCL KEY 11
11	SB1134912301	MAEHMESSERSATZ F. MAEHWER	2			ASSY, INCL KEYS 12, 13, 14 (SUB FOR SB1134907401)
12	SB1134905401	SCHRAUBE	1			
13	SB1134447901	SCHRAUBE	2			
14	SB9712083102	SICHERUNGSMUTTER	2			M8
15	19M7139	SECHSKANTSCHRAUBE	4			M8X20
16	14M7327	SICHERUNGSMUTTER	4			M8