

SA001793

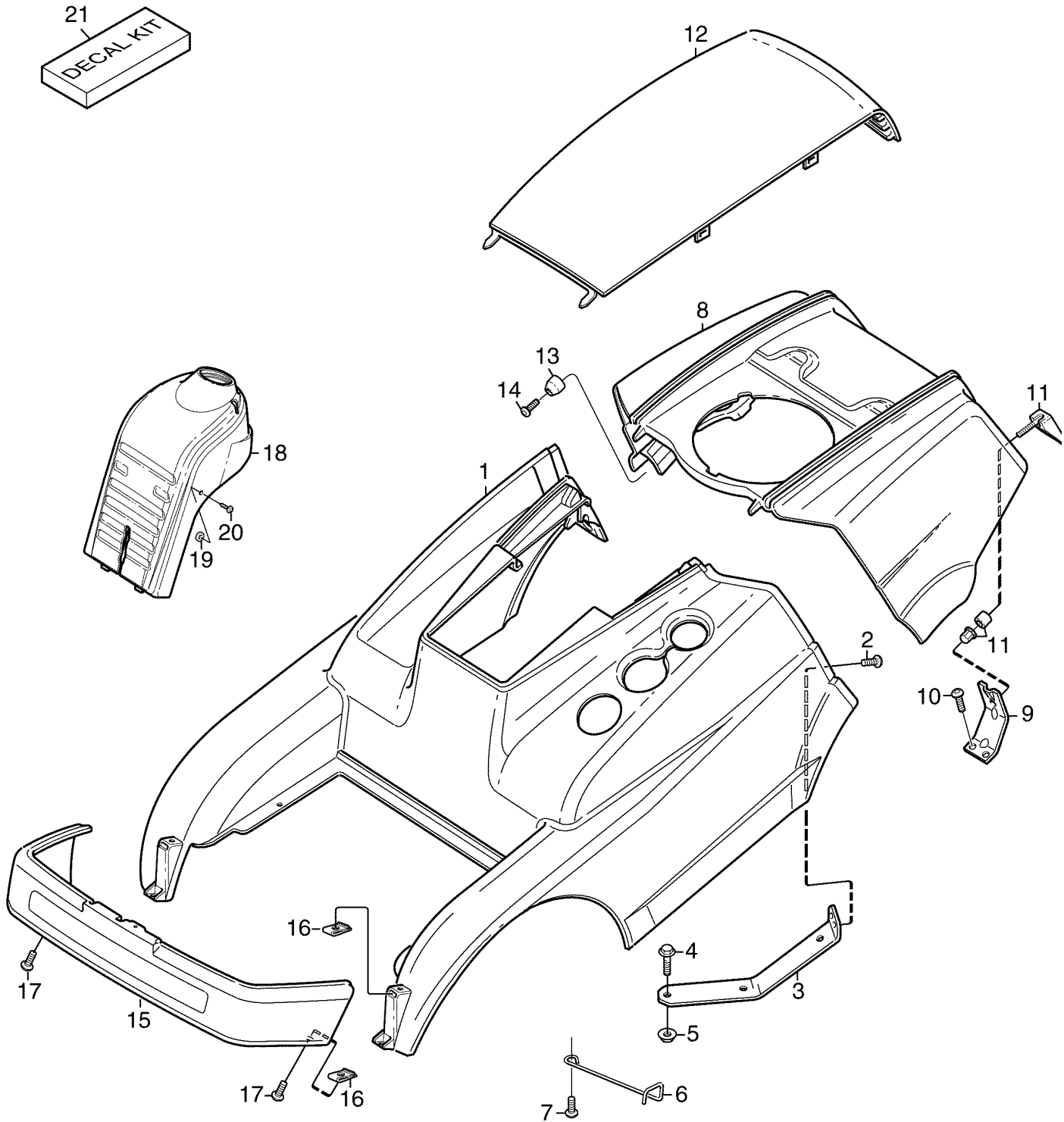

TEIL	STCK.NR	BEZEICHNUNG	STCK.	SER-NR.-	-SER-NR.	BEMERKUNG
1	SB1134466405	SACK	1			ASSY, INCL KEYS 2, 3, 4, 5, 6, 7, 8, 9,
2	ER024441	SPANNSTIFT	1			6X36
3	SB9699010302	UNTERLEGSCHLEIBE	1			16X38X0,5
4	SB9699011402	UNTERLEGSCHLEIBE	1			16X38X1,0
5	SB1134296002	MAUL-RINGSCHLUESSEL	1			5/8
6	SB1134454101	MAUL-RINGSCHLUESSEL	1			5/8/21 MM
7	SB1111211301	STANGE	1			
8	SB1134418501	UNTERLEGSCHLEIBE	2			
9	19M7866	SCHRAUBE	2			M8X20
10	SB1134260901	KNOPF	2			
11	24M7298	UNTERLEGSCHLEIBE	4			8,4X24X2,0
12	SB1134462701	STANGE	1			
13	19M7866	SCHRAUBE	2			M8X20
14	SB1134473401	SCHLUESSEL	1			
15	SB9837891412	SCHRAUBE	2			K7X14
16	SB9400006402	HALTER	1			



SA001794



TEIL	STCK.NR	BEZEICHNUNG	STCK.	SER-NR.-	-SER-NR.	BEMERKUNG
1	SB1134506704	HAUBE	1			FRONT
2	SB9893061616	SCHRAUBE	2			M6X16
3	SB1134444401	STUETZE	2			
4	19M7866	SCHRAUBE	4			M8X20
5	E63525	MUTTER	4			M8
6	SB1134507801	STUETZE	2			
7	SB9893061616	SCHRAUBE	2			M6X16
8	SB1134478704	HAUBE	1			REAR
9	SB1134538101	HAUBE	2			
10	SB9893061616	SCHRAUBE	4			M6X16
11	SB1134490401	ARRETIERUNG	2			
12	SB1134478903	DECKEL	1			
13	SB1134479002	HAUBE	2			
14	SB9838953012	SCHRAUBE	2			(SUB FOR SB9836953012)
15	SB1134394406	PUFFER	1			
16	SB1134417601	KLEMME	4			
17	SB9893061616	SCHRAUBE	6			M6X16
18	SB1134513902	PLATTE	1			
19	SB1134007000	UNTERLEGSSCHEIBE	2			
20	SB9852801916	SCHRAUBE	2			4,8X13
21	SB1134553602	AUFKLEBER-SATZ	1			

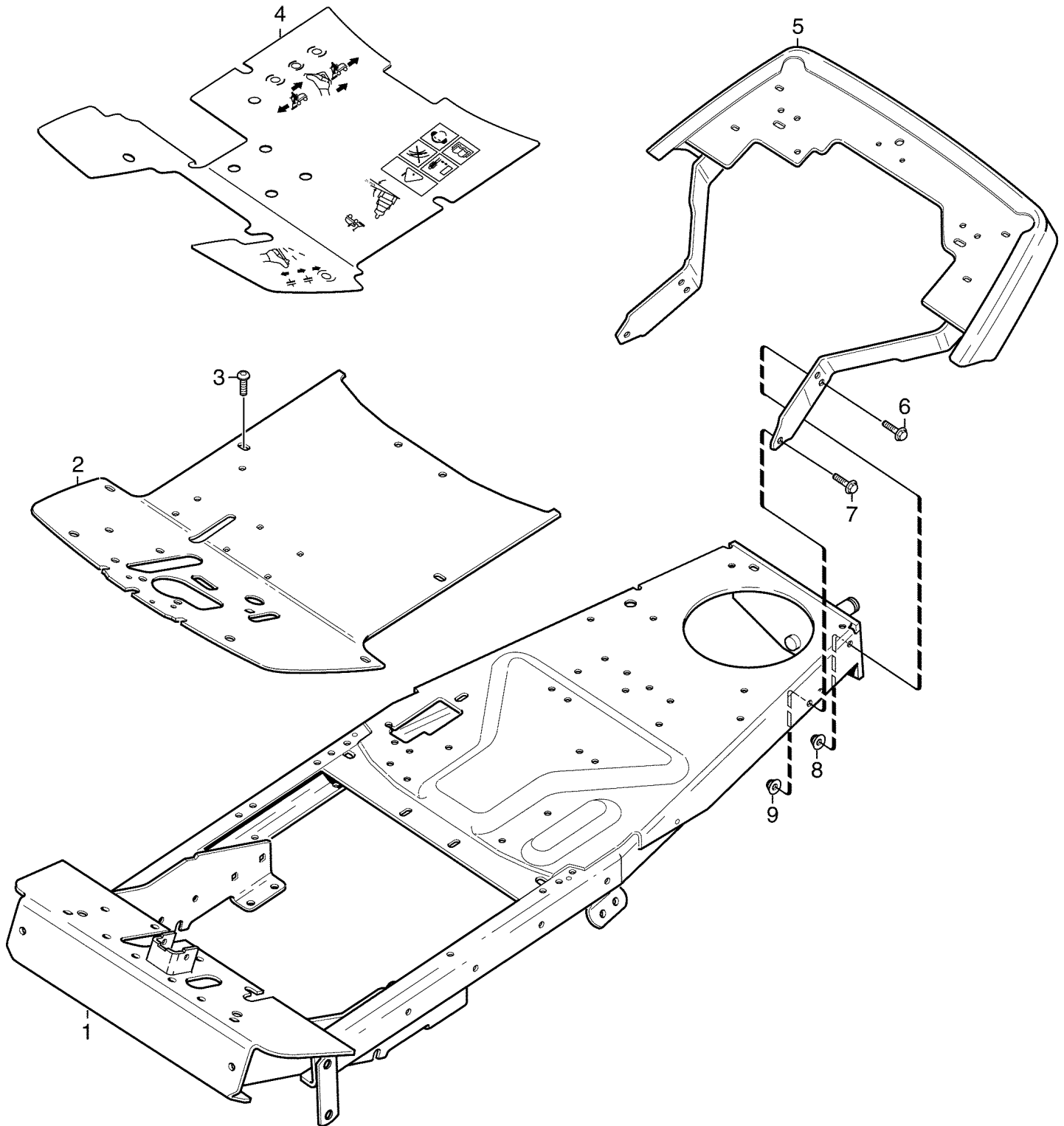

SA001795



TEIL	STCK.NR	BEZEICHNUNG	STCK.	SER-NR.-	-SER-NR.	BEMERKUNG
1	SB1134530902	RAHMEN	1			
2	SB1134529302	PLATTE	1			
3	SB9893061616	SCHRAUBE	2			M6X16
4	SB1134533902	MATTE	1			
5	SB1134538202	PUFFER	1			
6	19M7866	SCHRAUBE	2			M8X20
7	19M7867	SCHRAUBE	2			M8X25
8	E63525	MUTTER	3			M8
9	E63525	MUTTER	1			M8

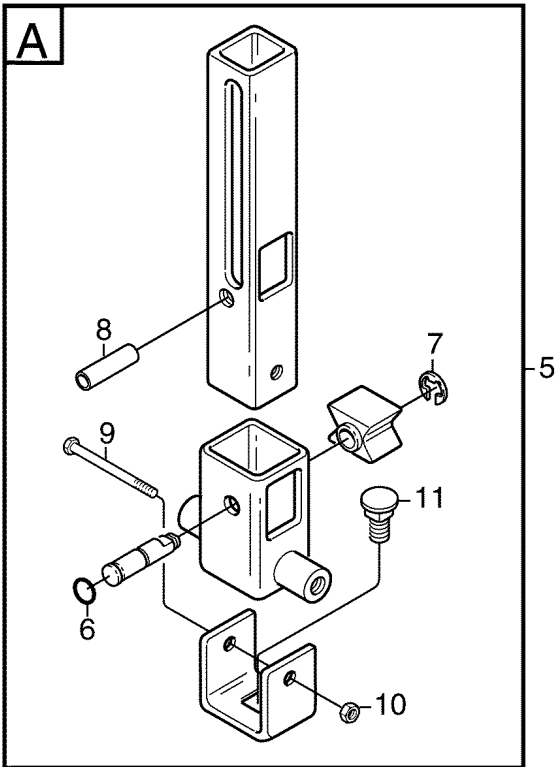
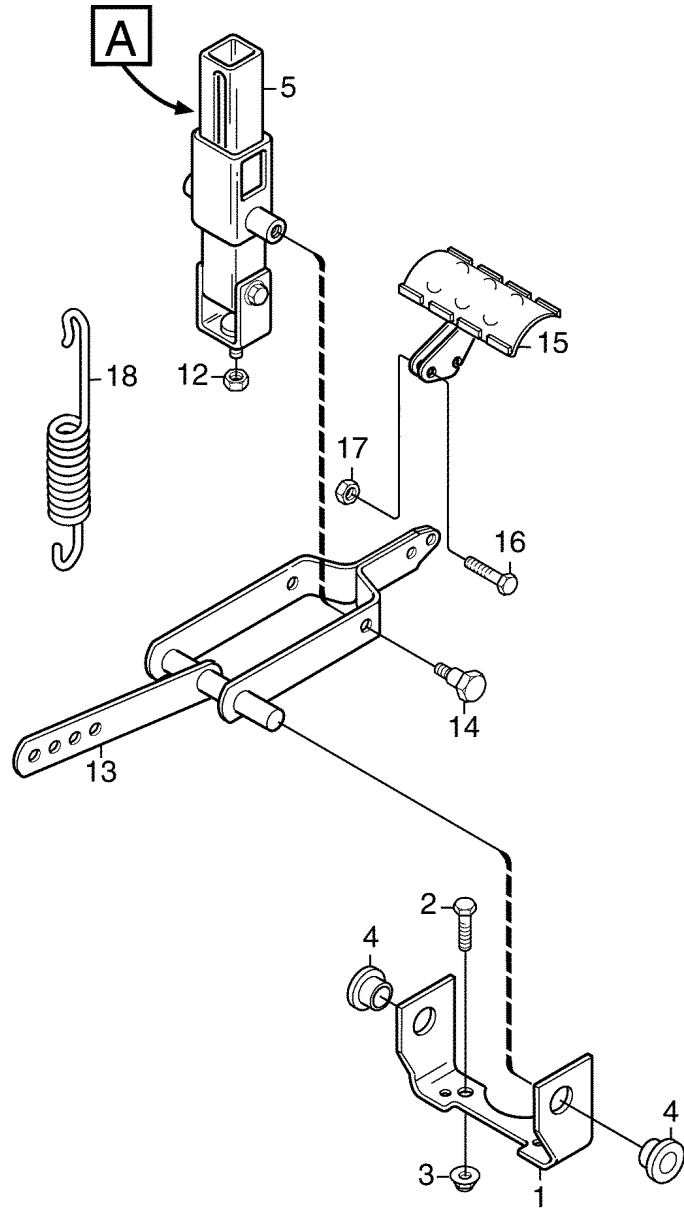

SA001796



TEIL	STCK.NR	BEZEICHNUNG	STCK.	SER-NR.-	-SER-NR.	BEMERKUNG
1	SB1134411701	KONSOLE	1			
2	19M7328	SECHSKANTSCHRAUBE	2			M10X70
3	CC19674	FLANSCHMUTTER	2			M10
4	SB1134268401	LAGER	2			
5	SB1134494501	VERSTELLVORRICHTUNG	1			ASSY, INCL KEYS 6, 7, 8, 9, 10, 11
6	T17951	O-RING	1			4,48X1,78
7	40M7144	SPRENGRING	1			
8	LCA05775	SPANNSTIFT	1			8X24
9	19M7320	SECHSKANTSCHRAUBE	1			M6X40
10	14M7165	SICHERUNGSMUTTER	1			M6
11	03M7054	FLACHRUNDSCHRAUBE	1			M8X20
12	14M7327	SICHERUNGSMUTTER	1			M8
13	SB1134486001	FLASCHENZUG	1			
14	SB1134024000	SCHRAUBE	2			
15	SB1134493801	FLASCHENZUG	1			
16	19M7286	SECHSKANTSCHRAUBE	2			M6X25
17	E63524	MUTTER	2			M6
18	SB4231001300	FEDER	1			

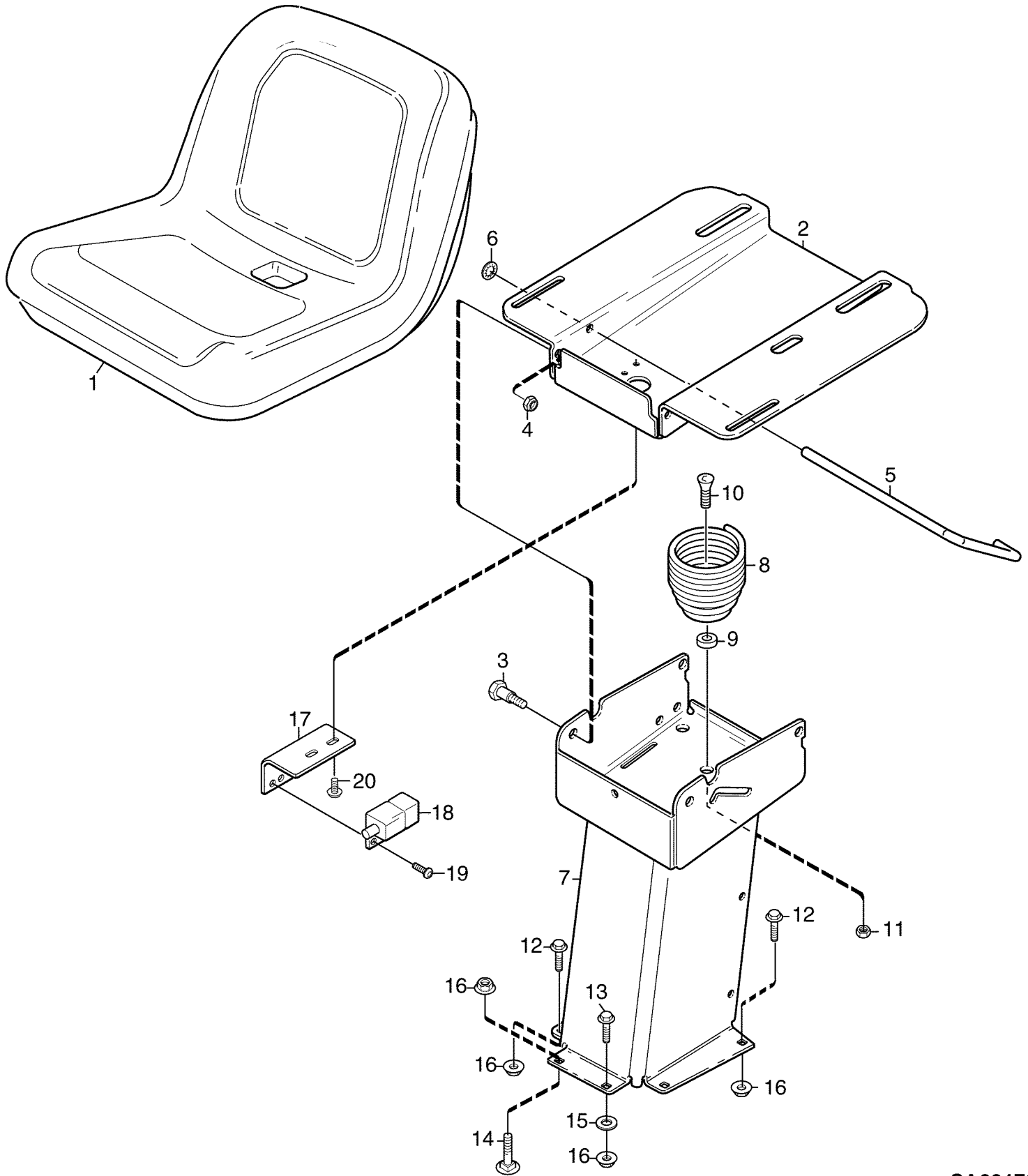

SA001797



TEIL	STCK.NR	BEZEICHNUNG	STCK.	SER-NR.-	-SER-NR.	BEMERKUNG
1	SB1134514401	SITZ	1			
2	SB1134462805	PLATTE	1			
3	SB1134024000	SCHRAUBE	2			
4	14M7327	SICHERUNGSMUTTER	2			M8
5	SB1134517901	SCHLIESSHAKEN	1			
6	SA34282	FEDERMUTTER	1			8,0
7	SB1134421102	KONSOLE	1			
8	SB1134425601	FEDER	1			
9	SB1134503201	DISTANZSTUECK	1			
10	SB9924123519	SCHRAUBE	1			M12X35
11	14M7168	SICHERUNGSMUTTER	1			M12
12	19M7866	SCHRAUBE	4			M8X20
13	19M7867	SCHRAUBE	1			M8X25
14	03M7054	FLACHRUNDSCHRAUBE	2			M8X20
15	24M7298	UNTERLEGSCHIEBE	1			8,4X24X2,0
16	E63525	MUTTER	7			M8
17	SB1134495002	KONSOLE	1			
18	SB1134339902	SCHALTER	1			
19	SB9852801316	SCHRAUBE	2			4,8X13
20	SB9893061616	SCHRAUBE	2			M6X16

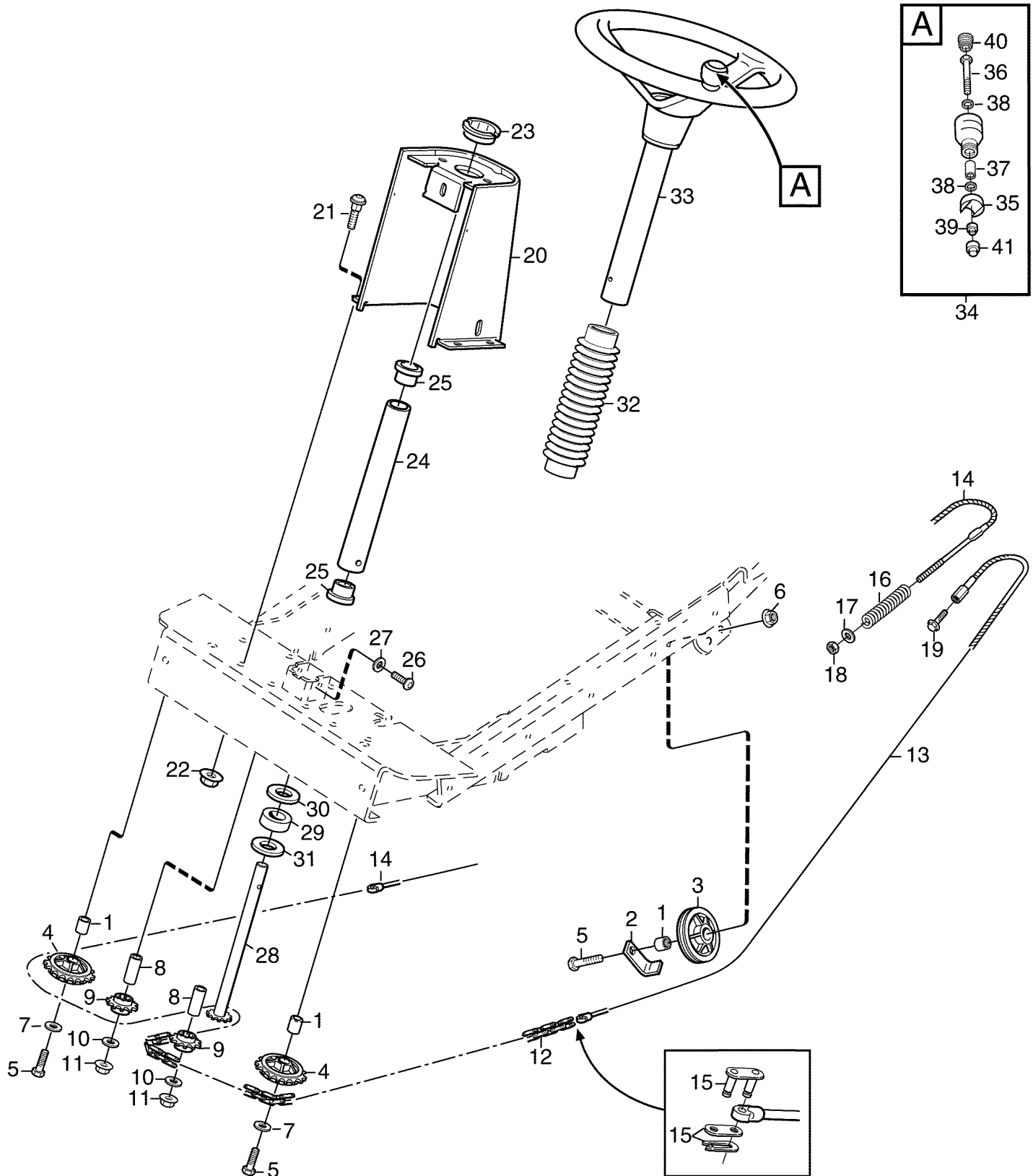

SA001798



TEIL	STCK.NR	BEZEICHNUNG	STCK.	SER-NR.-	-SER-NR.	BEMERKUNG
1	SB1134004101	BUECHSE	4			
2	SB1134302201	HALTER	2			
3	SB1134007200	RIEMENSCHLEIBE	2			
4	SB1134354701	KETTENRAD	2			
5	19M7382	SECHSKANTSCHRAUBE	4			M10X40
6	CC19674	FLANSCHMUTTER	2			M10
7	24M7134	UNTERLEGSCHLEIBE	2			10,5X22X2,0
8	SB1134004107	BUECHSE	2			
9	SB1134281601	KETTENRAD	2			
10	24M7134	UNTERLEGSCHLEIBE	2			10,5X22X2,0
11	CC19674	FLANSCHMUTTER	2			M10
12	SB1134282008	GLIEDERKETTE	1			L = 75
13	SB1134519201	KABEL	1			LH
14	SB1134519301	KABEL	1			RH
15	SB1134282401	SPANNSCHLOSS	2			
16	SB1134131001	DRUCKFEDER	1			
17	24M7298	UNTERLEGSCHLEIBE	1			8,4X24X2,0
18	14M7327	SICHERUNGSMUTTER	1			M8
19	19M7866	SCHRAUBE	1			M8X20
20	SB1134412007	SCHALTKONSOLE	1			
21	03M7054	FLACHRUNDSCHRAUBE	4			M8X20
22	E63525	MUTTER	4			M8
23	SB1134448301	BUECHSE	1			
24	SB1134130503	FUEHRUNG	1			
25	SB1134190101	LAGER	2			
26	SB9893061616	SCHRAUBE	2			M6X16
27	24M7139	UNTERLEGSCHLEIBE	2			6,4X18X2,0
28	SB1134282102	LENKSPINDEL	1			
29	SB1134304701	DISTANZSTUECK	2			
30	24M7053	UNTERLEGSCHLEIBE	1			17X30X3,0
31	SB1134283702	DISTANZSTUECK	1			
32	SB1134517801	BALG	1			
33	SB1134375402	LENKRAD	1			ASSY, INCL KEY 34
34	SB1134376901	KAPPE	1			ASSY, INCL KEYS 35, 36, 37, 38, 39, 40,
35	SB1134375201	HALTER	1			
36	19M7270	SECHSKANTSCHRAUBE	1			M8X65
37	SB1134156506	DISTANZSTUECK	1			
38	24M7132	UNTERLEGSCHLEIBE	2			8,4X18X1,5
39	14M7327	SICHERUNGSMUTTER	1			M8
40	SB9403004370	STOPFEN	1			
41	SB9403011300	SECHSKANTSCHRAUBE	1			

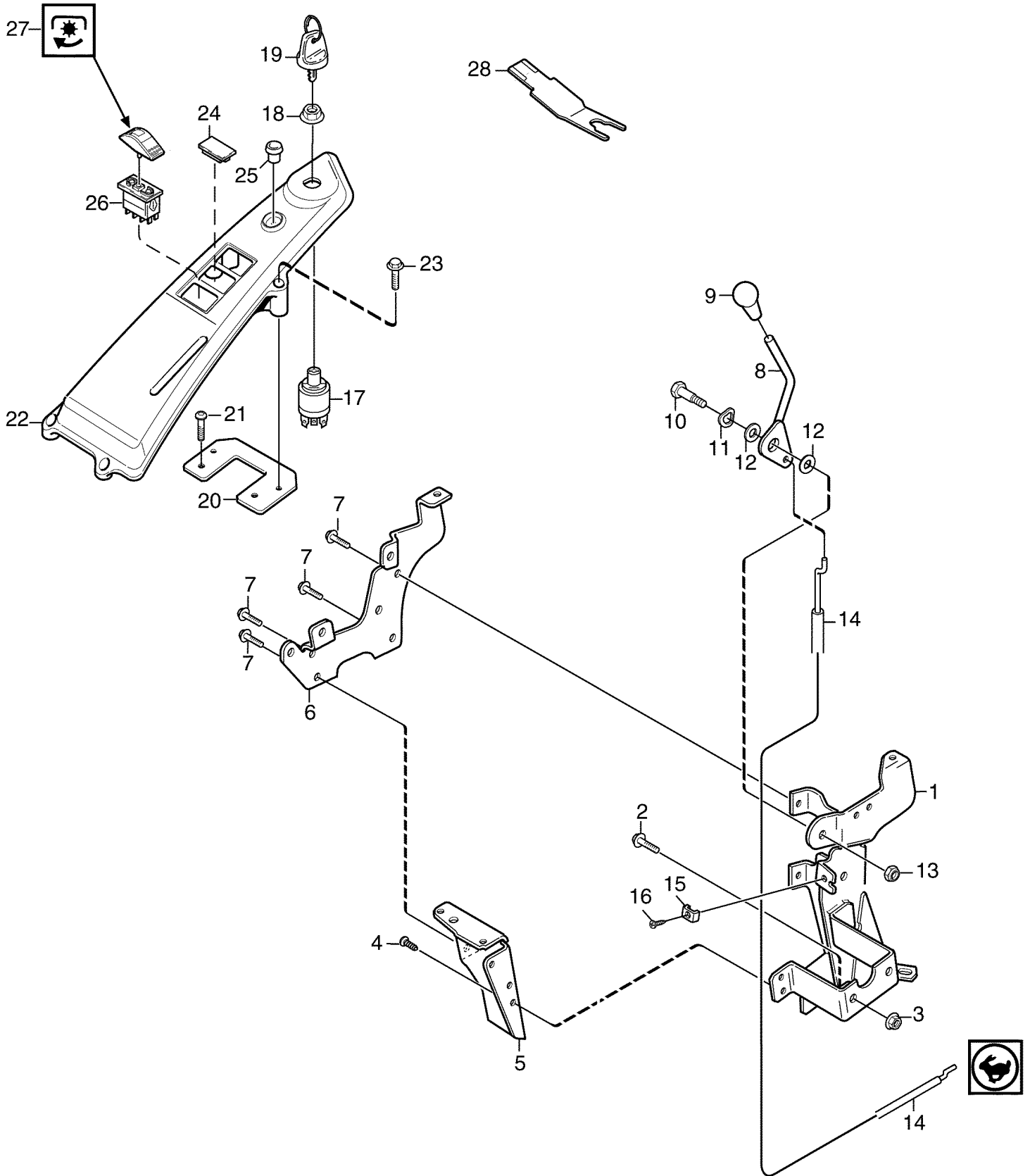

SA001800



TEIL	STCK.NR	BEZEICHNUNG	STCK.	SER-NR.-	-SER-NR.	BEMERKUNG
1	SB1134507701	KONSOLE	1			
2	19M7866	SCHRAUBE	2			M8X20
3	E63525	MUTTER	2			M8
4	SB9893061616	SCHRAUBE	2			M6X16
5	SB1134448702	KONSOLE	1			
6	SB1134398601	PLATTE	1			
7	SB9893061616	SCHRAUBE	4			M6X16
8	SB1134459001	STEUERUNG	1			
9	SB1134407801	KNOPF	1			
10	SB1134024000	SCHRAUBE	1			
11	SB9694000100	UNTERLEGSCHIEBE	1			13,5X20,5X0,5
12	SB1134424201	UNTERLEGSCHIEBE	2			
13	14M7327	SICHERUNGSMUTTER	1			M8
14	SB1134159711	KABEL	1			
15	LG691024	KLEMME	1			
16	SB9943051616	SCHRAUBE	1			M5X16
17	SB1134409301	SCHLUESSEL	1			
18	SB1134474901	MUTTER	1			
19	SB1134473401	SCHLUESSEL	1			
20	SB1134447201	PLATTE	1			
21	SB9943051616	SCHRAUBE	2			M5X16
22	SB1134447003	INSTRUMENTENTAFELTRAEGER	1			
23	SB9943051616	SCHRAUBE	4			M5X16
24	SB1134412901	DECKEL	2			
25	SB1134410001	STOPFEN	1			
26	SB9400028201	SCHALTER	1			
27	SB9400028001	DECKEL	1			PTO
28	SB9400029001	WERKZEUG	1			

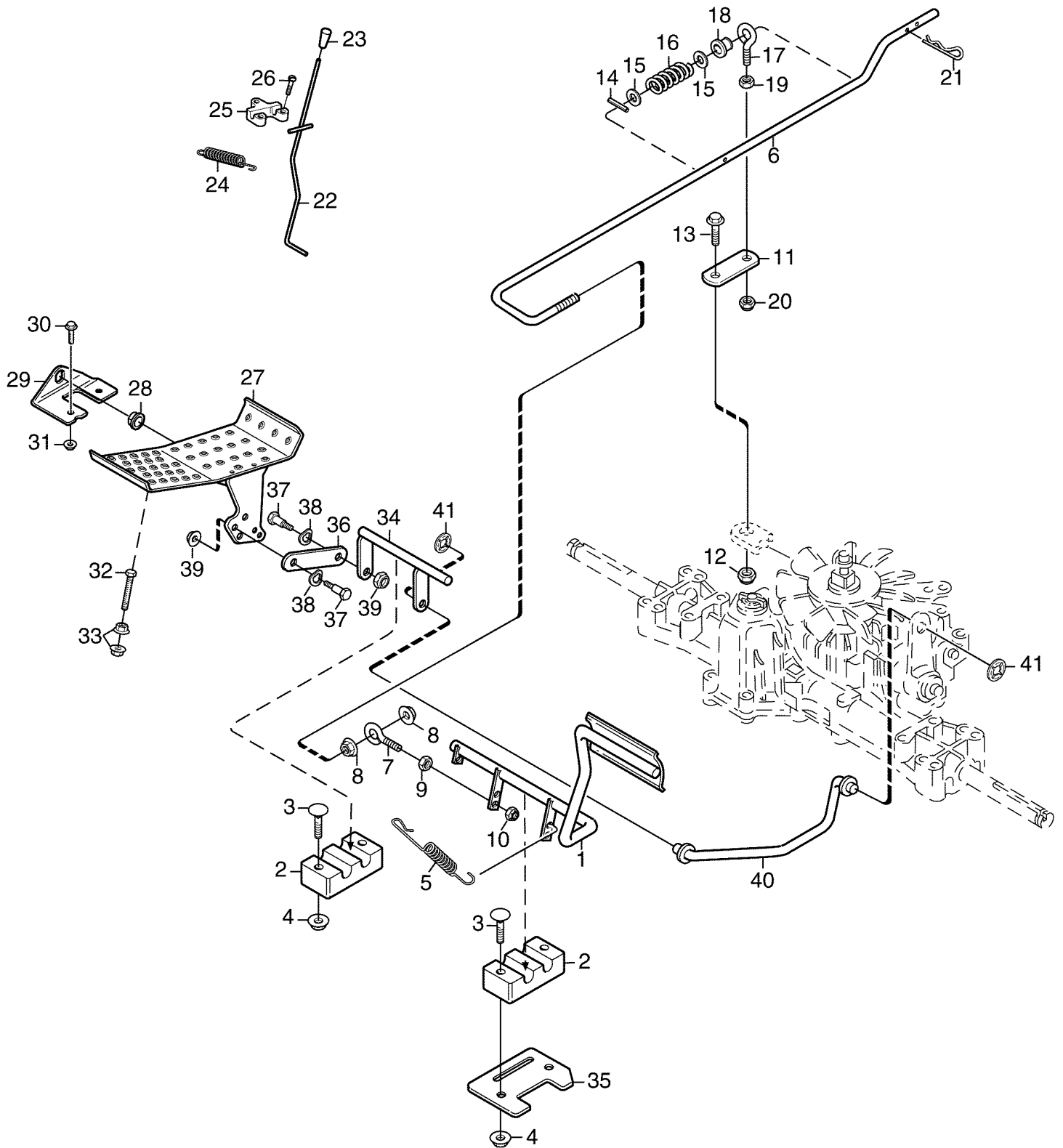

SA001801



TEIL	STCK.NR	BEZEICHNUNG	STCK.	SER-NR.-	-SER-NR.	BEMERKUNG
1	SB1134480201	PEDAL	1			
2	SB1134462401	LAGER	2			
3	03M7317	SCHRAUBE	4			M6X35
4	E63524	MUTTER	4			M6
5	SB4231001300	FEDER	1			
6	SB1134494901	STANGE	1			
7	SB1134213801	AUGENSCHRAUBE	1			
8	CC19674	FLANSCHMUTTER	2			M10
9	E63525	MUTTER	1			M8
10	14M7327	SICHERUNGSMUTTER	1			M8
11	SB1134497201	VERBINDUNGSGLIED	1			
12	14M7327	SICHERUNGSMUTTER	1			M8
13	SB9997082016	SCHRAUBE	1			(SUB FOR 19M7866)
14	34M7130	SPANNSTIFT	1			4X20
15	24M7134	UNTERLEGSCHIEBE	2			10,5X22X2,0
16	SB1134461701	FEDER	1			
17	SB1134213801	AUGENSCHRAUBE	1			
18	SB1134477901	BUECHSE	1			
19	E63525	MUTTER	1			M8
20	14M7327	SICHERUNGSMUTTER	1			M8
21	J16931	STIFT	1			2,5MM
22	SB1134510101	STANGE	1			
23	SB1134380801	KNOPF	1			
24	SB1131149701	FEDER	1			
25	SB1134400201	STANGE	1			
26	SB9838951612	SCHRAUBE	3			K5X16
27	SB1134400803	PEDAL	1			(SUB FOR SB1134400801)
28	SB1134278001	LAGER	2			
29	SB1134270001	KONSOLE	2			
30	19M7866	SCHRAUBE	2			M8X20
31	E63525	MUTTER	2			M8
32	19M3138	SECHSKANTSCHRAUBE	1			M8X70
33	E63525	MUTTER	2			M8
34	SB1134444001	WELLE	1			
35	SB1134479301	PLATTE	1			
36	SB1134444101	VERBINDUNGSGLIED	1			
37	SB1134024000	SCHRAUBE	2			
38	SB9694000100	UNTERLEGSCHIEBE	2			13,5X20,5X0,5
39	14M7327	SICHERUNGSMUTTER	2			M8
40	SB1134448201	STANGE	1			
41	SA34282	FEDERMUTTER	2			8,0



TEIL	STCK.NR	BEZEICHNUNG	STCK.	SER-NR.-	-SER-NR.	BEMERKUNG
1	SB1134480401	TROCKEN GELADENE BATTERIE	1			
2	SB1134461001	KONSOLE	1			
3	SB1134339902	SCHALTER	1			
4	SB9852801316	SCHRAUBE	2			4,8X13
5	SB9579000300	HALTER	3			
6	SB1134204202	KABEL	1			BLACK
7	SB9838951612	SCHRAUBE	2			K5X16
8	24M7139	UNTERLEGSCHIEBE	1			6,4X18X2,0
9	14M7327	SICHERUNGSMUTTER	1			M8
10	14H850	MUTTER	1			1/4-20 UNC
11	SB9579000300	HALTER	2			
12	SB1134349101	SICHERUNGSHALTER	1			
13	SB1134363101	DECKEL	1			
14	SB9838951612	SCHRAUBE	2			K5X16
15	SB1134349601	ELEKTRISCHE SICHERUNG	1			10A
15	SB1134349606	ELEKTRISCHE SICHERUNG	1			20A
16	SB1134516001	KABELBAUM	1			
17	SB1134287103	RELAIS	1			
18	SB1134390101	MAGNETSPULE	1			
19	SB1134470201	KABEL	1			RED
20	SB1134470202	KABEL	1			RED
21	SB1134497002	SEILZUG	1			
22	14H650	MUTTER	2			5/16-24 UNF
23	SB1134231001	SCHUTZ	1			

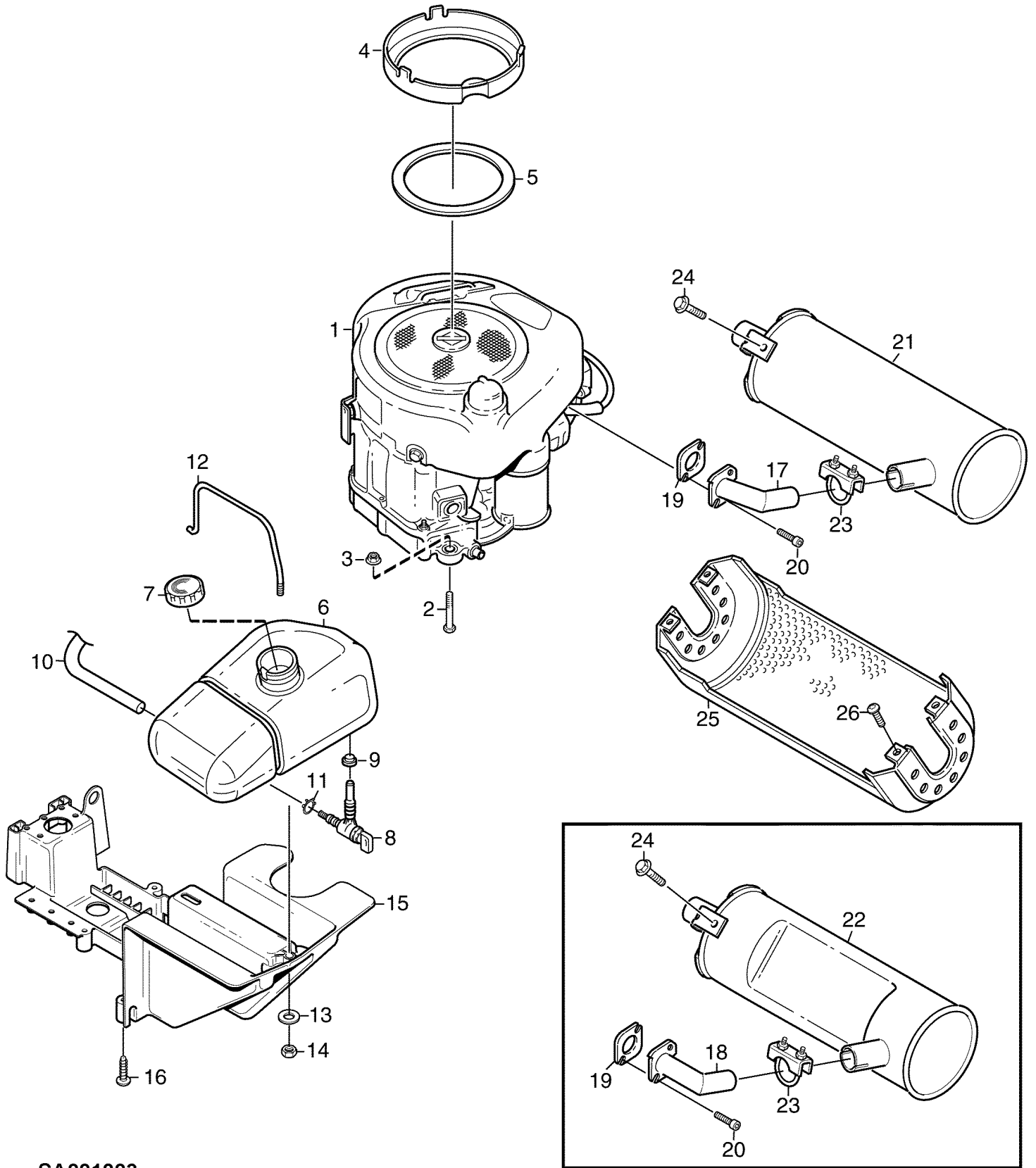

SA001803



TEIL	STCK.NR	BEZEICHNUNG	STCK.	SER-NR.-	-SER-NR.	BEMERKUNG
1		BENZINMOTOR	1			(A) B&S MODEL 282H07, TYP 0113-E1
2	19M7922	SECHSKANTSCHRAUBE	4			M8X40
3	14M7327	SICHERUNGSMUTTER	4			M8
4	SB1134446801	DISTANZSTUECK	1			39.5
5	SB1134422202	RING	1			
6	SB1134506601	KRAFTSTOFFBEHAELTER	1			
7	SB1134287703	EINFUELLVERSCHLUSS	1			
8	SB1134322401	VERSCHLUSSSCHRAUBE	1			
9	SB1134322501	GUMMIMUFFE	1			
10	SB1134297505	SCHLAUCH	1			LGTH = 460 MM
11	SB9578002302	SCHLAUCHKLEMME	2			
12	SB1134480801	KLEMME	1			
13	24M7139	UNTERLEGSCHEIBE	1			6,4X18X2,0
14	14M7165	SICHERUNGSMUTTER	1			M6
15	SB1134480702	KONSOLE	1			
16	SB9829883012	SCHRAUBE	4			K6X30
18	SB1134538001	AUSPUFFROHR	1			
19	SB1134043300	DICHTUNG	1			
20	SB1134493001	SCHRAUBE	2			
22	SB1134537701	SCHALLDAEMPFER	1			
23	SB9578001101	KLEMME	1			(SUB FOR SB9578001100)
24	19M7866	SCHRAUBE	1			M8X20
25	SB1134516301	SCHUTZ	1			
26	SB9893061616	SCHRAUBE	4			M6X16
(A) ERSATZTEILE BEIM BRIGGS & STRATTON HAENDLER BESTELLEN						

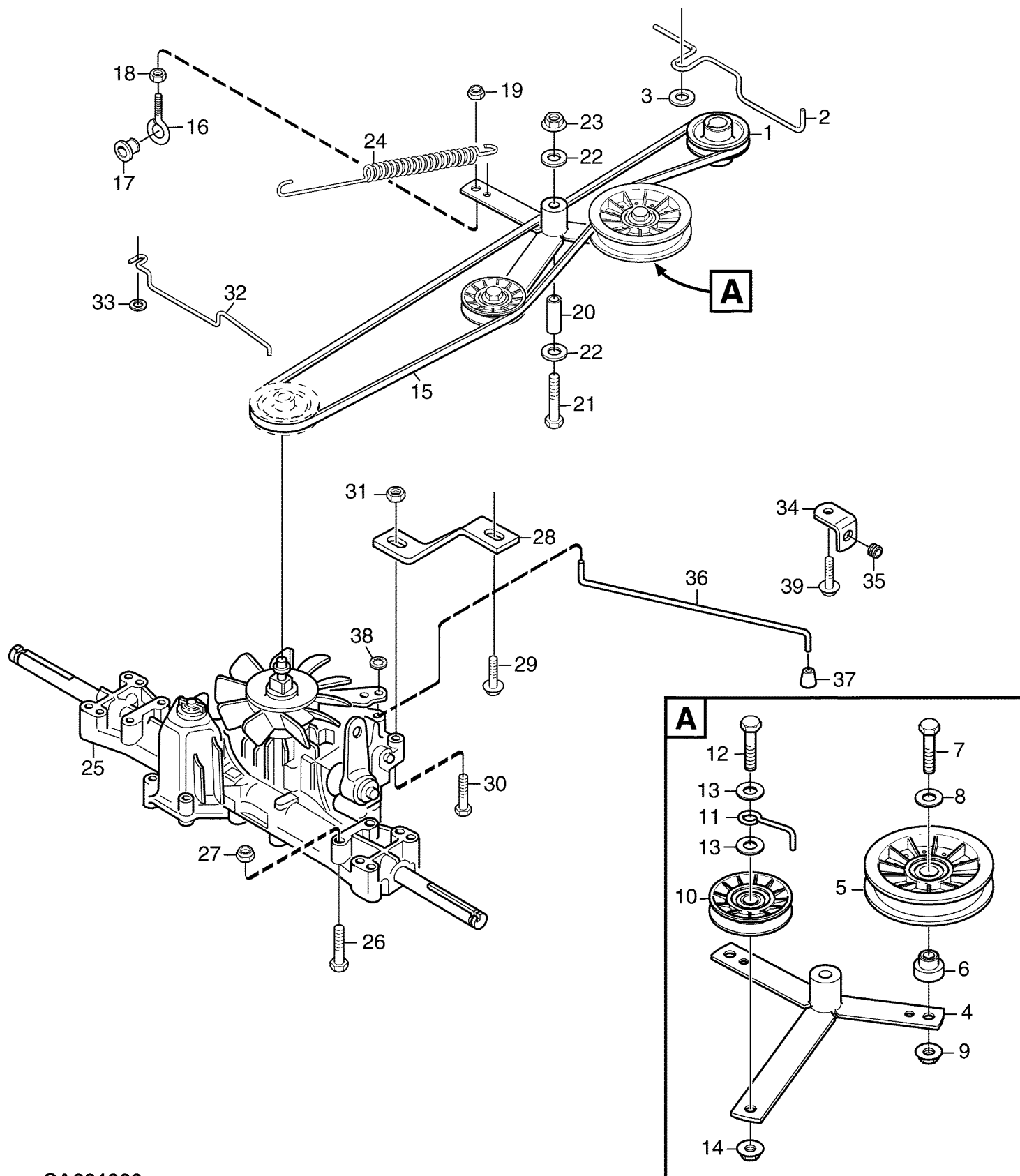

SA001806



TEIL	STCK.NR	BEZEICHNUNG	STCK.	SER-NR.-	-SER-NR.	BEMERKUNG
1	SB1134461101	RIEMENSCHLEIBE	1			
2	SB1134541401	FUEHRUNG	1			
3	24M7298	UNTERLEGSCHLEIBE	1			8,4X24X2,0
4	SB1134451901	ARM	1			
5	SB1134305301	SPANNROLLE	1			
6	SB1134461401	DISTANZSTUECK	1			
7	19M7382	SECHSKANTSCHRAUBE	1			M10X40
8	24M7134	UNTERLEGSCHLEIBE	1			10,5X22X2,0
9	CC19674	FLANSCHMUTTER	1			M10
10	SB1134298902	SPANNROLLE	1			(SUB FOR SB1134298901)
11	SB1134179501	WINKEL	1			
12	19M7382	SECHSKANTSCHRAUBE	1			M10X40
13	24M7134	UNTERLEGSCHLEIBE	2			10,5X22X2,0
14	CC19674	FLANSCHMUTTER	1			M10
15	SB9585009901	KEILRIEMEN	1			
16	SB1134213801	AUGENSCHRAUBE	1			
17	SB1134477901	BUECHSE	1			
18	E63525	MUTTER	1			M8
19	14M7327	SICHERUNGSMUTTER	1			M8
20	SB1134156508	DISTANZSTUECK	1			
21	SB9997086512	SCHRAUBE	1			(SUB FOR 19M3138)
22	24M7298	UNTERLEGSCHLEIBE	2			8,4X24X2,0
23	E63525	MUTTER	1			M8
24	SB1134521401	FEDER	1			
25	SB1134484601	TRANSACHSE	1			KANZAKI K46AG
26	SB9997086512	SCHRAUBE	4			(SUB FOR 19M3138)
27	14M7327	SICHERUNGSMUTTER	4			M8
28	SB1134458801	STUETZE	1			
29	SB9945081616	SCHRAUBE	1			M8X16
30	19M7922	SECHSKANTSCHRAUBE	1			M8X40
31	14M7327	SICHERUNGSMUTTER	1			M8
32	SB1134531901	FUEHRUNG	1			
33	24M7298	UNTERLEGSCHLEIBE	1			8,4X24X2,0
34	SB1134471301	KONSOLE	1			
35	SB1134279001	FUEHRUNG	1			
36	SB1134515601	STANGE	1			
37	SB1134401401	DRUCKKNOPF	1			
38	SB9675000902	FEDERRING	1			6,0
39	SB9945081616	SCHRAUBE	1			M8X16

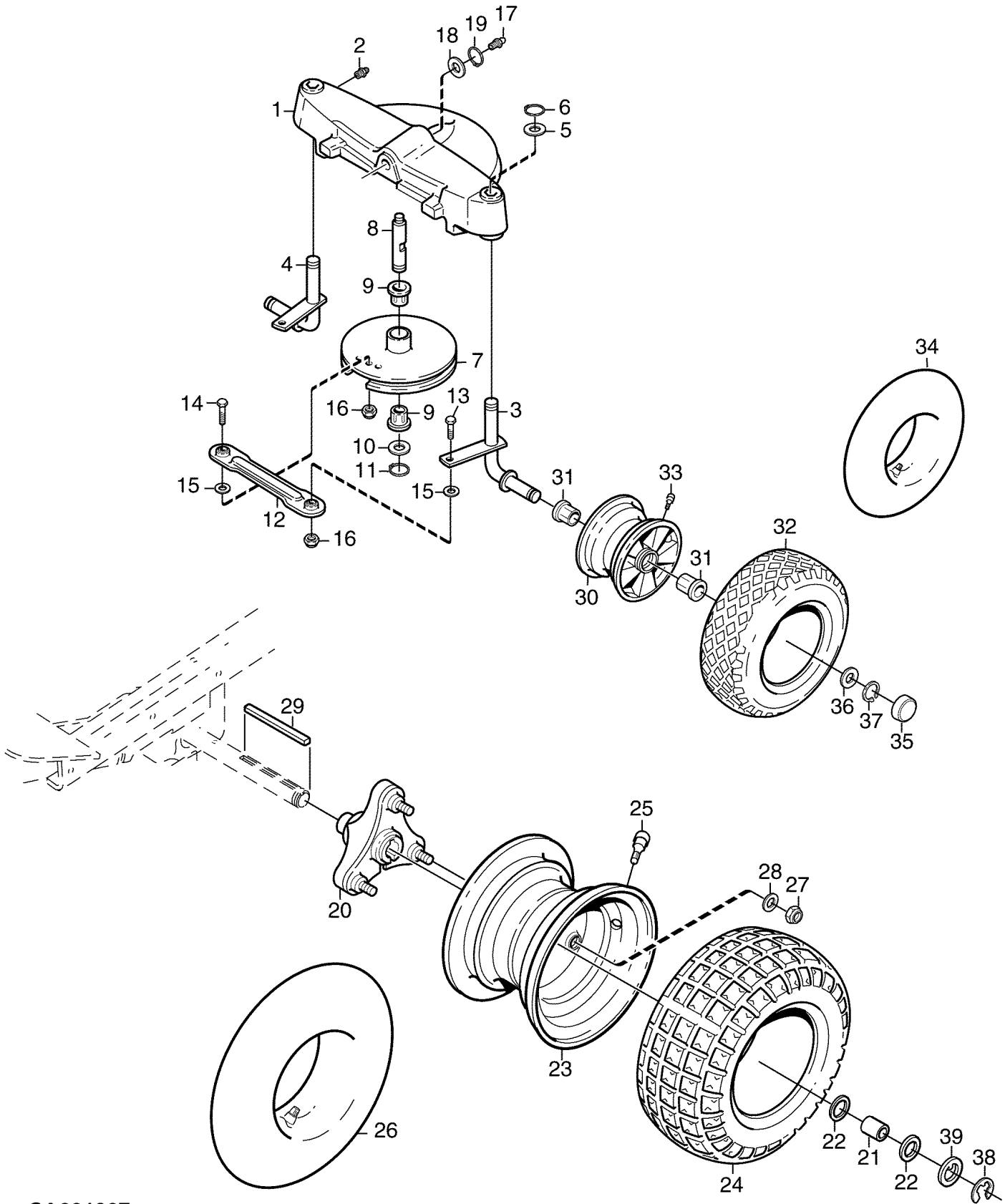

SA001807



TEIL	STCK.NR	BEZEICHNUNG	STCK.	SER-NR.-	-SER-NR.	BEMERKUNG
1	SB1134501201	HINTERACHSE	1			REAR
2	58M5573	SCHMIERNIPPEL	2			M6
3	SB1134500902	SPINDEL	1			LH
4	SB1134500901	SPINDEL	1			RH
5	L115418	UNTERLEGSCHIEBE	2			20X30X3,0
6	40M7080	SPRENGRING	2			
7	SB1134150003	RIEMENSCHIEBE	1			
8	SB1134158301	RIEMENSCHIEBE	1			
9	SB1134006800	LAGER	2			
10	SB1134034101	UNTERLEGSCHIEBE	1			
11	40M7080	SPRENGRING	1			
12	SB1134324705	STANGE	2			
13	19M7163	SECHSKANTSCHRAUBE	2			M8X25
14	19M8008	SECHSKANTSCHRAUBE	1			M8X35
15	24M7055	UNTERLEGSCHIEBE	2			8,4X16X1,5
16	14M7327	SICHERUNGSMUTTER	3			M8
17	58M5573	SCHMIERNIPPEL	1			M6
18	L115418	UNTERLEGSCHIEBE	1			20X30X3,0
19	40M7080	SPRENGRING	1			
20	SB1134484402	RADBOLZEN	2			
21	SB1134484501	HUELSE	2			
22	SB1134034101	UNTERLEGSCHIEBE	4			
23	SB1134455803	FELGE	2			
24	SB9545011600	REIFEN	2			16X7.50 - 8
25	SB9545050000	VENTIL	2			
26	SB9545020300	SCHLAUCH	2			
27	14M7167	SICHERUNGSMUTTER	6			M10
28	24M7134	UNTERLEGSCHIEBE	6			10,5X22X2,0
29	SB1134247103	SCHLUESSEL	2			
30	SB1134470603	FELGE	2			
31	SB1134131901	LAGER	4			
32	SB9545012501	REIFEN	2			14X5.50 - 6
33	SB9545050000	VENTIL	2			
34	SB9545020400	SCHLAUCH	2			
35	SB1134434401	KAPPE	2			
36	SB1134034101	UNTERLEGSCHIEBE	2			
37	40M7080	SPRENGRING	2			
38	SB9653000104	RING	2			
39	SB1134498101	UNTERLEGSCHIEBE	2			

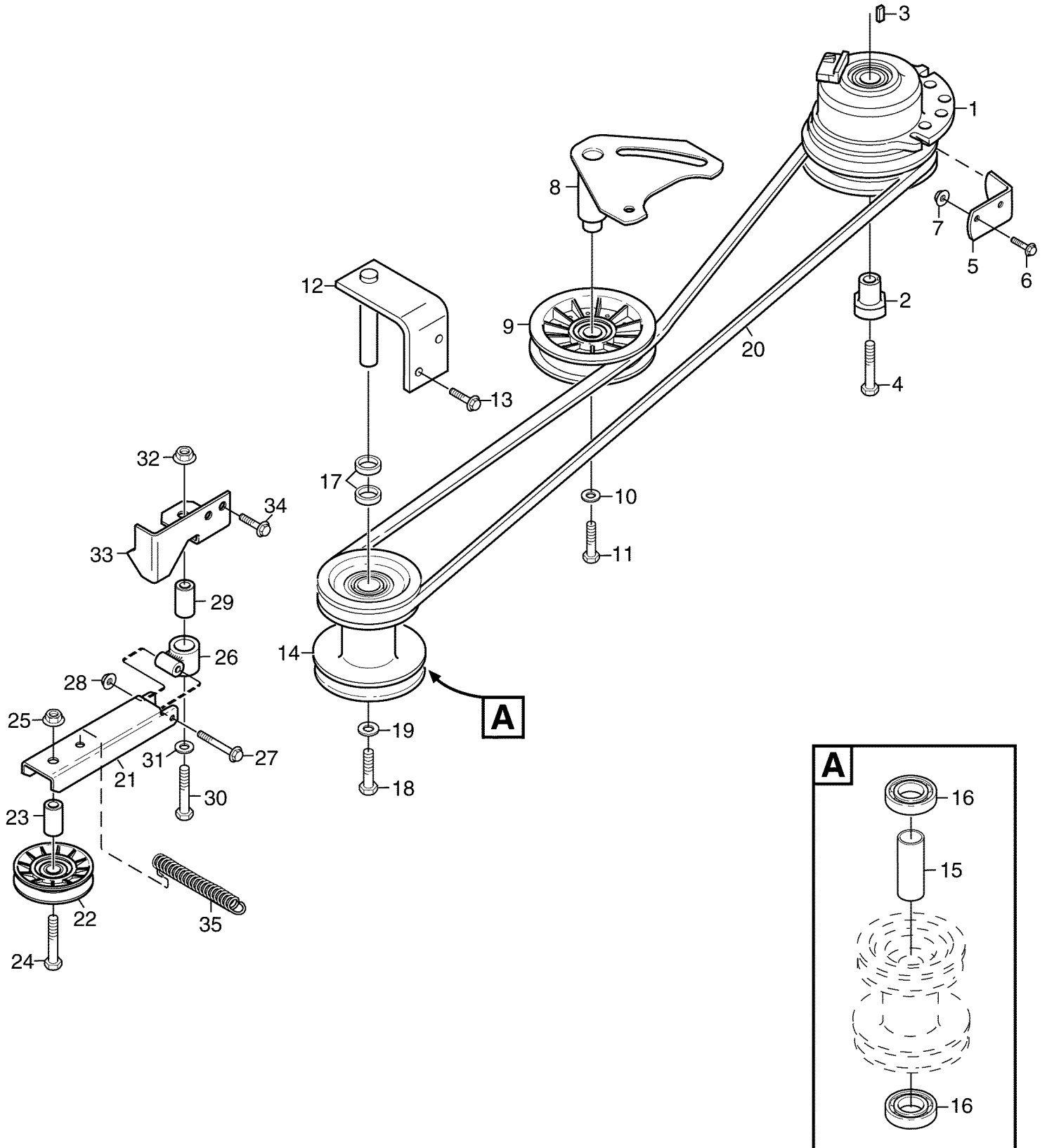

SA001809



TEIL	STCK.NR	BEZEICHNUNG	STCK.	SER-NR.-	-SER-NR.	BEMERKUNG
1	SB1134467201	KUPPLUNG	1			ASSY, INCL KEY 2
2	SB1134501601	BUECHSE	1			
3	H64374	KEIL	1			
4	19H2503	SECHSKANTSCHRAUBE	1			7/16-20 UNFX57
5	SB1134467901	STUETZE	1			
6	19M7866	SCHRAUBE	1			M8X20
7	E63525	MUTTER	1			M8
8	SB1134453802	KONSOLE	1			
9	SB1134305301	SPANNROLLE	1			
10	24M7298	UNTERLEGSCHIEBE	1			8,4X24X2,0
11	19M7866	SCHRAUBE	1			M8X20
12	SB1134465001	RIEMENSCHIEBE	1			
13	SB9945081616	SCHRAUBE	2			M8X16
14	SB1134464301	RIEMENSCHIEBE	1			ASSY, INCL KEYS 15, 16
15	SB1134005112	DISTANZSTUECK	1			
16	SB9549001900	KUGELLAGER	2			
17	SB1134005200	DISTANZSTUECK	2			
18	19M7382	SECHSKANTSCHRAUBE	1			M10X40
19	24M7134	UNTERLEGSCHIEBE	1			10,5X22X2,0
20	SB9585012501	KEILRIEMEN	1			
21	SB1134523101	ARM	1			
22	SB1134298902	SPANNROLLE	1			(SUB FOR SB1134298901)
23	SB1134461901	DISTANZSTUECK	1			
24	19M7156	SECHSKANTSCHRAUBE	1			M10X60
25	CC19674	FLANSCHMUTTER	1			M10
26	SB1134523201	HALTER	1			
27	19M7320	SECHSKANTSCHRAUBE	1			M6X40
28	14M7165	SICHERUNGSMUTTER	1			M6
29	SB1134461901	DISTANZSTUECK	1			
30	19M7382	SECHSKANTSCHRAUBE	1			M10X40
31	24M7134	UNTERLEGSCHIEBE	1			10,5X22X2,0
32	CC19674	FLANSCHMUTTER	1			M10
33	SB1134470802	KONSOLE	1			
34	SB9945081616	SCHRAUBE	2			M8X16
35	SB1131150700	FEDER	1			