

This catalog covers:
FJ180V-□S19

GRID NO. This grid covers:
A-01 TITLE

PARTS CATALOG

4-STROKE ENGINE

FJ180V

PRODUCT CODE	NOTE
FJ180V-AS19	WBM

PARTS CATALOG INTRODUCTION

This parts catalog lists parts and sub-assemblies provided as service parts. When it becomes necessary to replace parts, always use KAWASAKI GENUINE PARTS which have passed strict inspection which guarantees quality and performance.

1. HOW TO ORDER PARTS

- When ordering the parts, be sure to use the parts catalog corresponding to the product code. Check the product revision codes on the product and the catalog.
 Product Code (example) : FA130D-**A**A00
 Product Revision Code
- Specify the part code (all digits) exactly as listed in this catalog on your parts order.
- The parts not shown in the illustrations of this catalog are not sold separately; only the complete units or next higher assemblies illustrated are supplied as the service parts.

2. EXPLANATION OF PARTS CATALOG FORMAT

This catalog covers: **FH500V-□S14**

GRID NO. **B-03** This grid covers: **CYLINDER/CRANKCASE**

E01110-A274B

Ref. No.	Part No.	Description	Quantity	
			A	B
11004	11004-7001	GASKET-HEAD	2	2
11008	11008-7001	HEAD-COMP-CYLINDER#1	1	1
11008A	11008-7002	HEAD-COMP-CYLINDER#2	1	1
11022	11022-7001	CASE-ROCKER	2	2
11060	11060-7001	GASKET,ROCKER CASE	2	2
11060A	11060-7008	GASKET,CRANKCASE COVER	1	1
11060B	11060-7015	GASKET,BREATHER	1	1
13271	13271-7016	PLATE	1	1
13271A	13271-7016	PLATE	1	1
14690	14690-7001	COVER,BREATHER	1	1
49015	49015-6215	COVER,CRANKCASE	1	1
49109	49109-7002	ELEMENT-BREATHER	1	1
49120	49120-6119	CRANKCASE-COMP	1	1
92033	92033-7003	RING-SNAP	2	2
92043	92043-7001	PIN	6	6
92049	92049-7001	SEAL-OIL	4	4
92049A	92049-7002	SEAL-OIL	1	1
92049B	92049-7004	SEAL-OIL	1	1
92049C	92049-7005	SEAL-OIL	1	1
130	130B0612	BOLT-FLANGED	4	4
130A	130B0640	BOLT-FLANGED	4	4
130B	130T0650	BOLT-FLANGED	17	17
130C	130T0875	BOLT-FLANGED	2	2
172	172G0818	BOLT-STUD	4	4

1) Product Code

This code describes the product code covered by this catalog. The product revision code, which is a part of the product code, is omitted.

2) Part Group Title

This title is the representative name for the group of parts illustrated on the page.

3) Reference Number

The reference numbers are shown on the illustration and the list as the link between them.

4) Part Number

This is the key of your parts ordering. Three kinds of part number are used in this catalog.

- Structure 1
- Structure 2
- Standard Hardware Number (for bolts, nuts, washer, or the like)

5) Description and Additional Information

The part name, the location, the size, and the serial number as additional information, etc. are described here. Use them to find out and check the part required.

When a part number is changed without change of the product revision code and the changed parts are not interchangeable, the serial number of the product is noted as follows;

- (FA130 - 100001) : Affected units are from beginning of the product of the product code up to and including this serial number.
 (FA130 - 100002 -) : Affected units are from this serial number and above.
 (FA130 - 100002 - FA130 - 110001) : Affected units are in this serial number range.

6) Quantity

The figure shows quantity of the part required at the indicated position on the illustration and for the specified product revision code.

The asterisk (*) on this column means the part can be used as the substitute on the product and is supplied until the stock is exhausted.

Note:Some small parts will be supplied by units.

Example: If six (6) bolts are ordered and the minimum quantity per unit is five (5), two (2), units of the bolt will be delivered.

7) Product Revision Code

This Code indicates an important change which affects the service parts interchangeability.

3. ABBREVIATIONS

#.....Number	FR.....Front	RH.....Right Hand
&.....And	G.....Gram	RPM.....Revolutions Per Minute
(+).....Plus	HEX.....Hexagonal	RR.....Rear
(-).....Minus	ID=.....Inside Diameter	STD.....Standard
2ND.....Second	IN.....Inch	T.....Teeth
3RD.....Third	L=.....Length	T=.....Thickness
4TH.....Fourth	LH.....Left Hand	U/S.....Under Size
A.....Ampere	LWR.....Lower	UPP.....Upper
AR.....As Required	MM.....Millimeter	V.....Volt
ASSY.....Assembly	O/S.....Over Size	W.....Watt
CNT.....Center	OD=.....Outside Diameter	
COMP.....Complete	REF.....Reference	

This catalog covers:
FJ180V- □ S19

GRID NO. This grid covers:
B-01 PICTORIAL INDEX

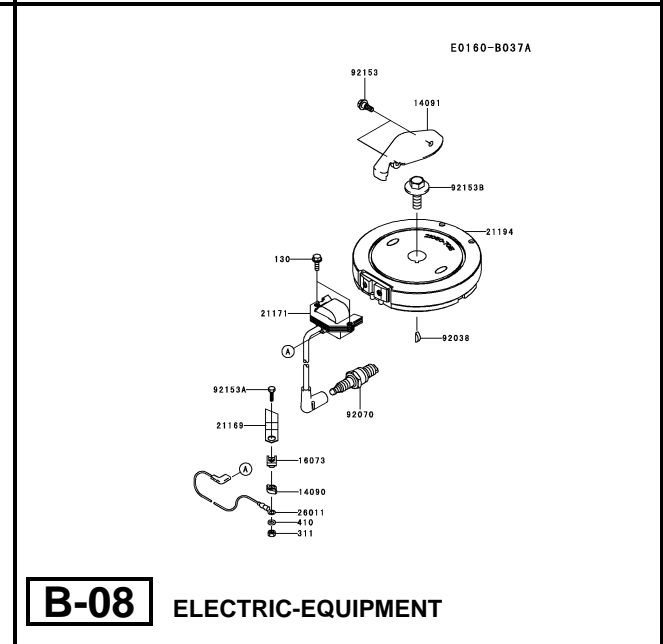
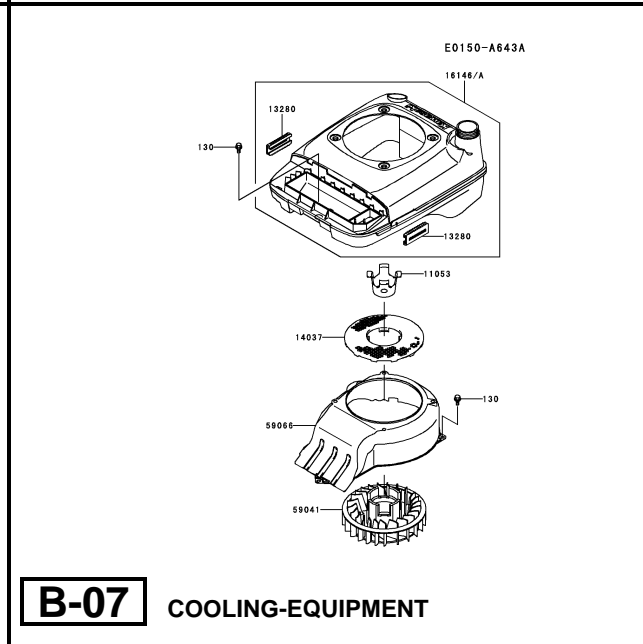
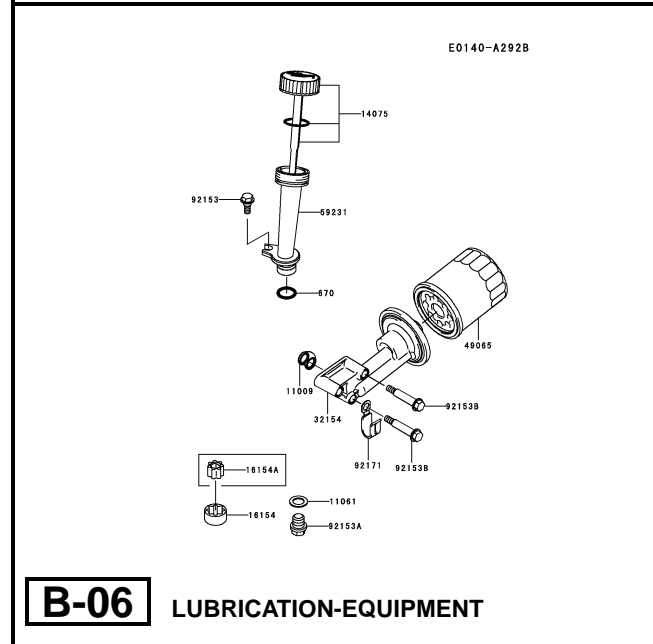
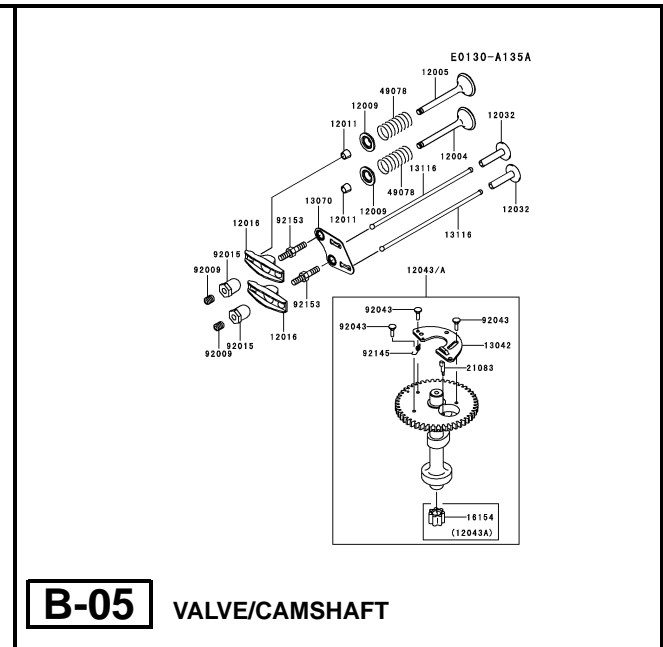
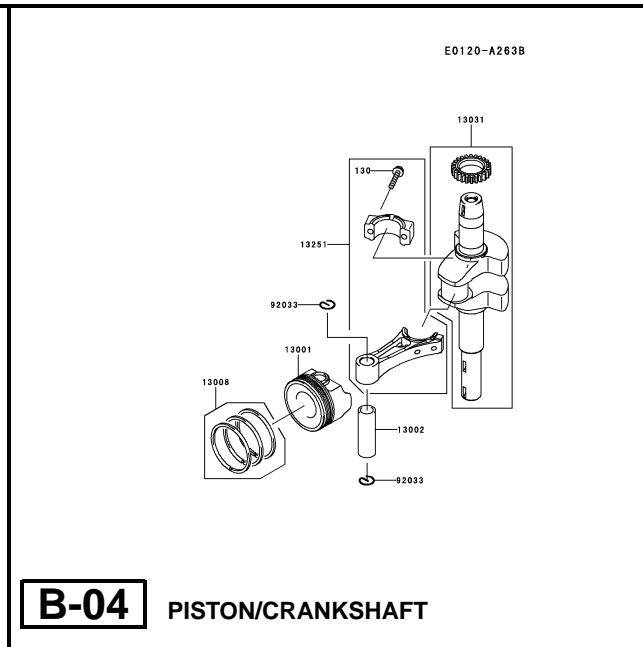
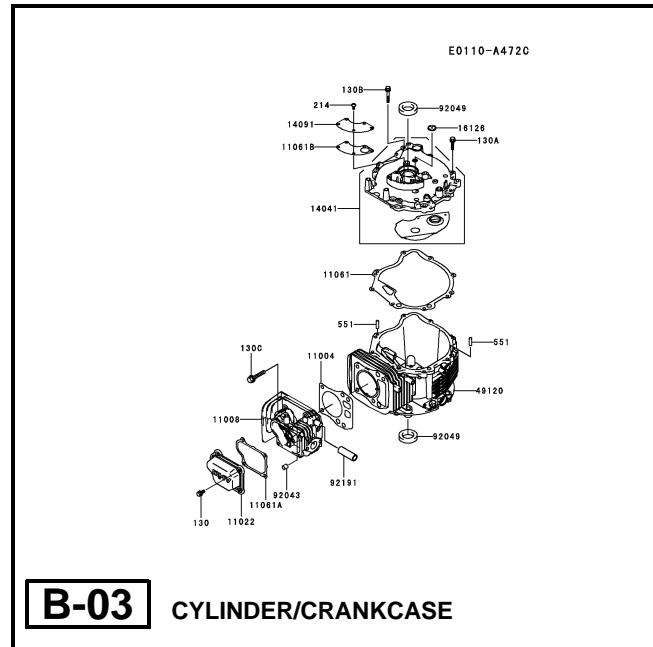

This catalog covers:
FJ180V- □ S19

GRID NO. This grid covers:
B-02 PICTORIAL INDEX

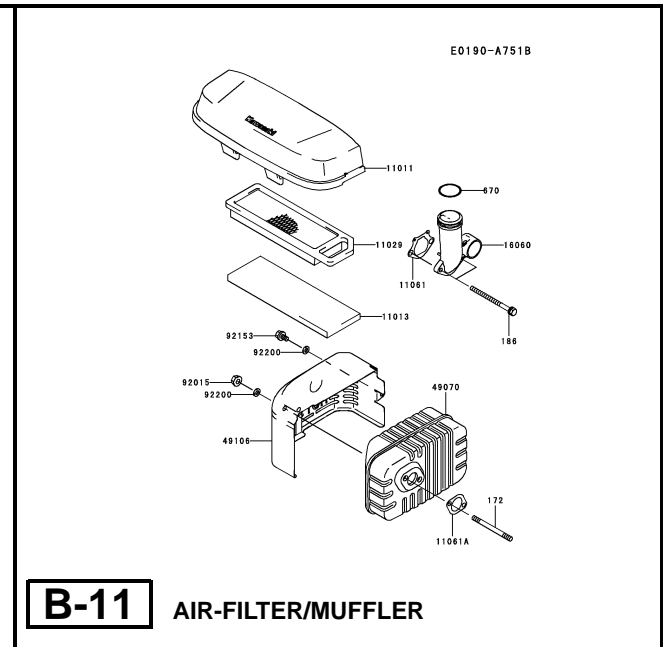
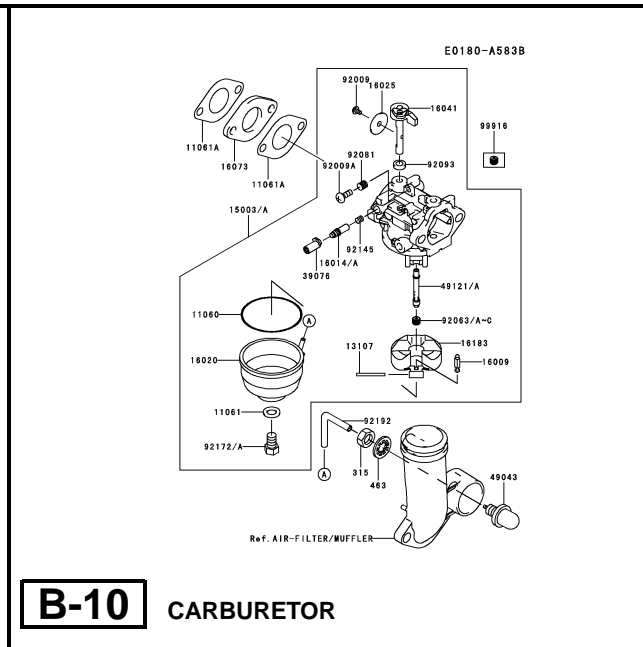
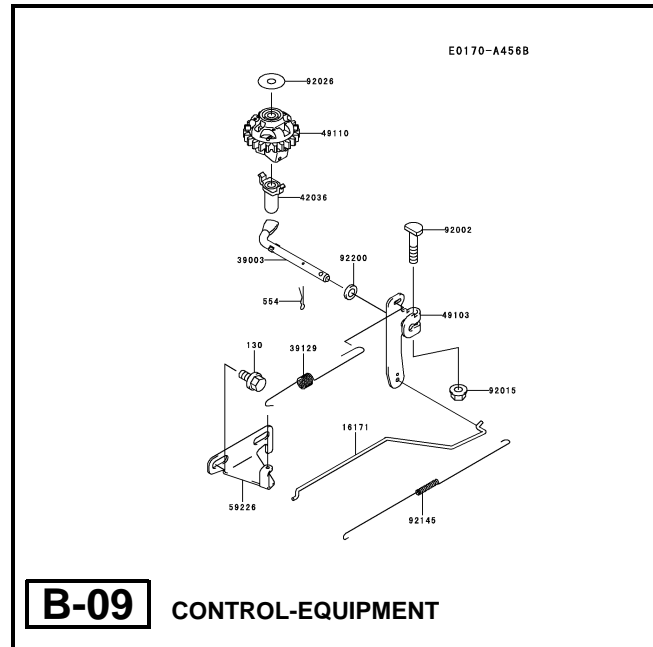

This catalog covers:

FJ180V- □ S19

GRID NO.

C-01

This grid covers:

PICTORIAL INDEX

E0200-A445D

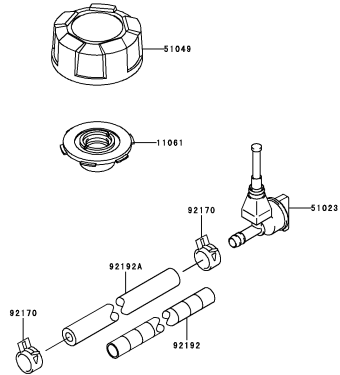

C-03

FUEL-TANK/FUEL-VALVE

E0210-A279B

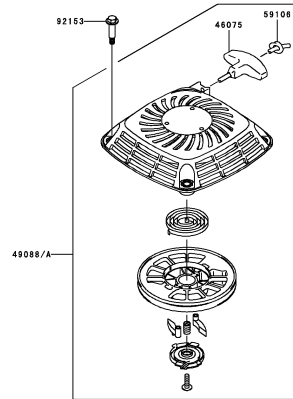

C-04

STARTER

This catalog covers:

FJ180V- □ S19

GRID NO.

D-01

This grid covers:

PICTORIAL INDEX

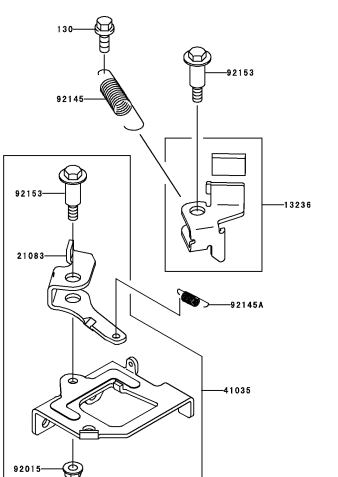
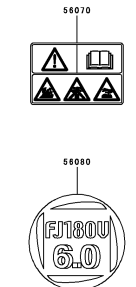
<p>F0220-A013A</p>  <p>D-03 BRAKE/COVER</p>	<p>F0290-B072A</p>  <p>D-04 LABEL</p>	

This catalog covers:

FJ180V- □ S19

GRID NO.

B-03

This grid covers:

CYLINDER/CRANKCASE

E0110-A472C

Ref. No.	Part No.	Description	Quantity
11004	11004-7020	GASKET-HEAD	1
11008	11008-7025	HEAD-COMP-CYLINDER	1
11022	11022-7005	CASE-ROCKER	1
11061	11061-7020	GASKET,COVER-CRANKCASE	1
11061A	11061-7023	GASKET,CASE ROCKER	1
11061B	11061-7031	GASKET,BREATHER	1
14041	14041-7002	COVER-COMP	1
14091	14091-7010	COVER,BREATHER	1
16126	16126-7014	VALVE,BREATHER	1
49120	49120-7046	CRANKCASE-COMP	1
92043	92043-7001	PIN	2
92049	92049-7008	SEAL-OIL,28-44-9 TC	2
92191	92191-7025	TUBE,12X16X49	1
130	130B0612	BOLT-FLANGED	4
130A	130G0625	BOLT-FLANGED	7
130B	130G0635	BOLT-FLANGED	1
130C	130T0840	BOLT-FLANGED	4
214	214B0510	SCREW-PAN+-	5
551	551A0612	PIN-DOWEL	2

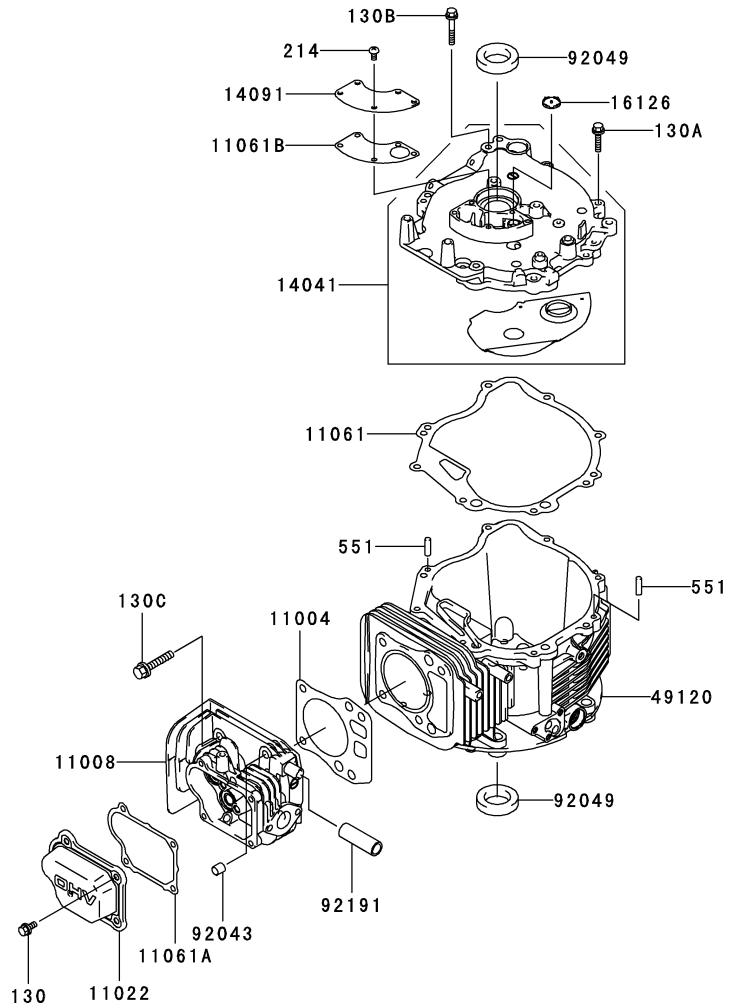

This catalog covers:

FJ180V- □ S19

GRID NO.

B-04

This grid covers:

PISTON/CRANKSHAFT

E0120-A263B

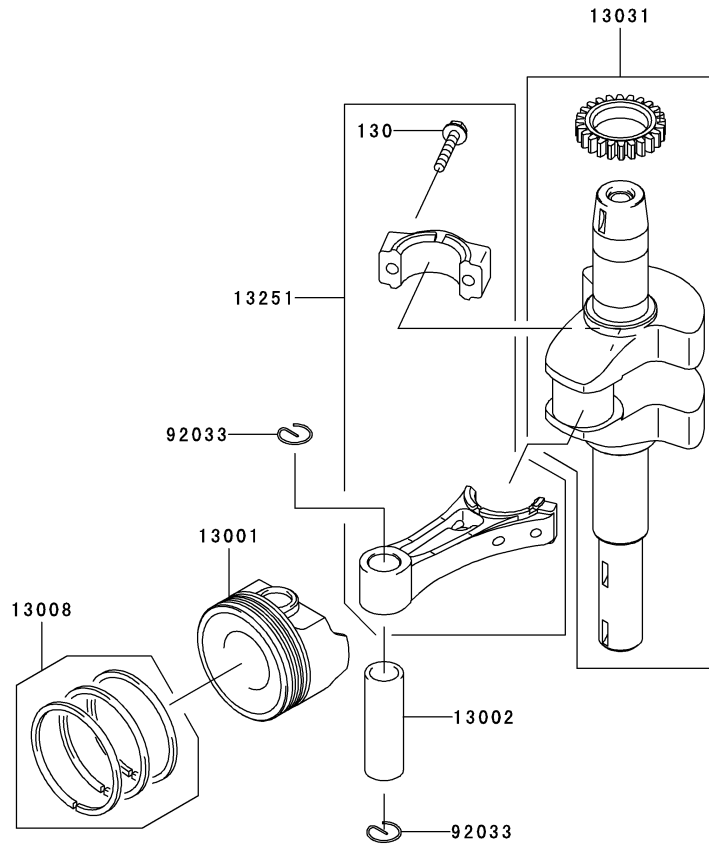

Ref. No.	Part No.	Description	Quantity
13001	13001-7009	PISTON-ENGINE	1
13002	13002-7001	PIN-PISTON	1
13008	13008-7001	RING-SET-PISTON	1
13031	13031-7065	CRANKSHAFT-COMP	1
13251	13251-7011	ROD-ASSY-CONNECTING	1
92033	92033-7005	RING-SNAP	2
130	130G0630	BOLT-FLANGED	2

This catalog covers:
FJ180V- □ S19

GRID NO.
B-05

This grid covers:
VALVE/CAMSHAFT

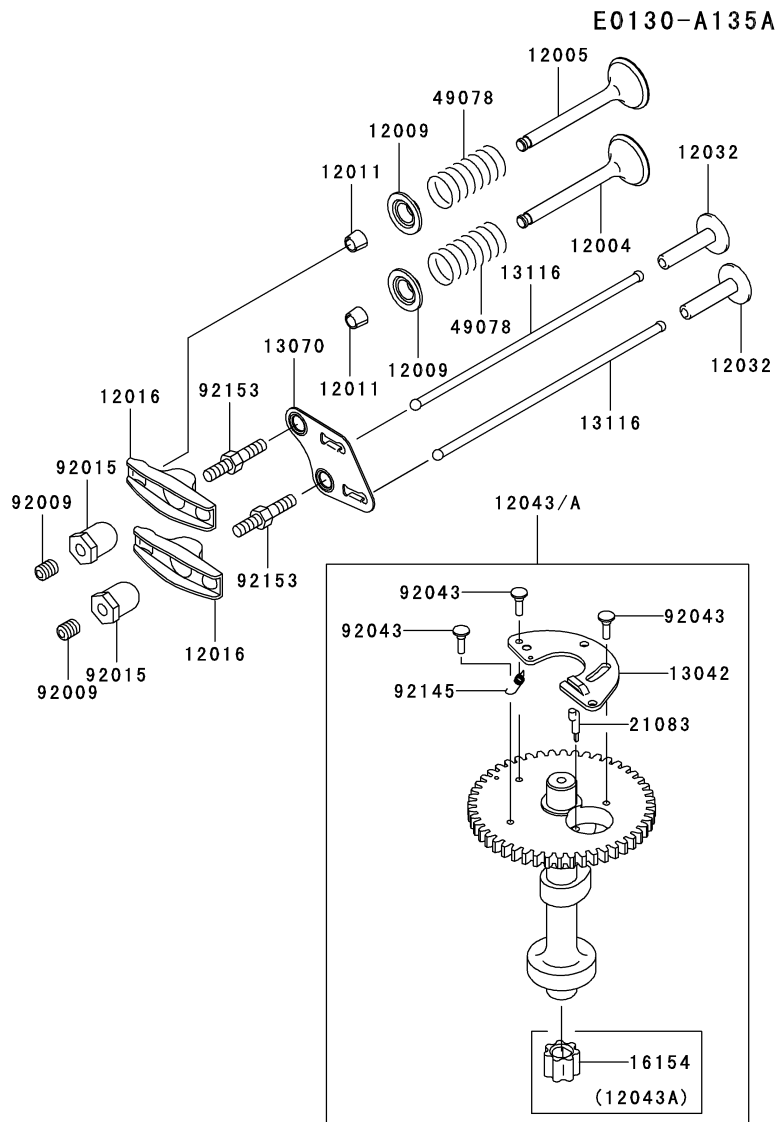

Ref. No.	Part No.	Description	Quantity
		A	
12004	12004-7005	VALVE-INTAKE	1
12005	12005-7006	VALVE-EXHAUST	1
12009	12009-7001	RETAINER-VALVE SPRING	2
12011	12011-2056	COLLET	4
12016	12016-7001	ARM-ROCKER	2
12032	12032-7001	TAPPET	2
12043	12043-7004	CAMSHAFT-ASSY-VALVE	*
12043A	12043-7005	CAMSHAFT-ASSY-VALVE	1
13042	13042-7006	WEIGHT	1
13070	13070-7009	GUIDE	1
13116	13116-7003	ROD-PUSH	2
16154	16154-7004	ROTOR-PUMP	1
21083	21083-7009	ARM	1
49078	49078-7001	SPRING-ENGINE VALVE	2
92009	92009-2341	SCREW	2
92015	92015-2253	NUT	2
92043	92043-7006	PIN	3
92145	92145-7016	SPRING	1
92153	92153-7019	BOLT	2

This catalog covers:

FJ180V- □ S19

GRID NO.

B-06

This grid covers:

LUBRICATION-EQUIPMENT

E0140-A292B

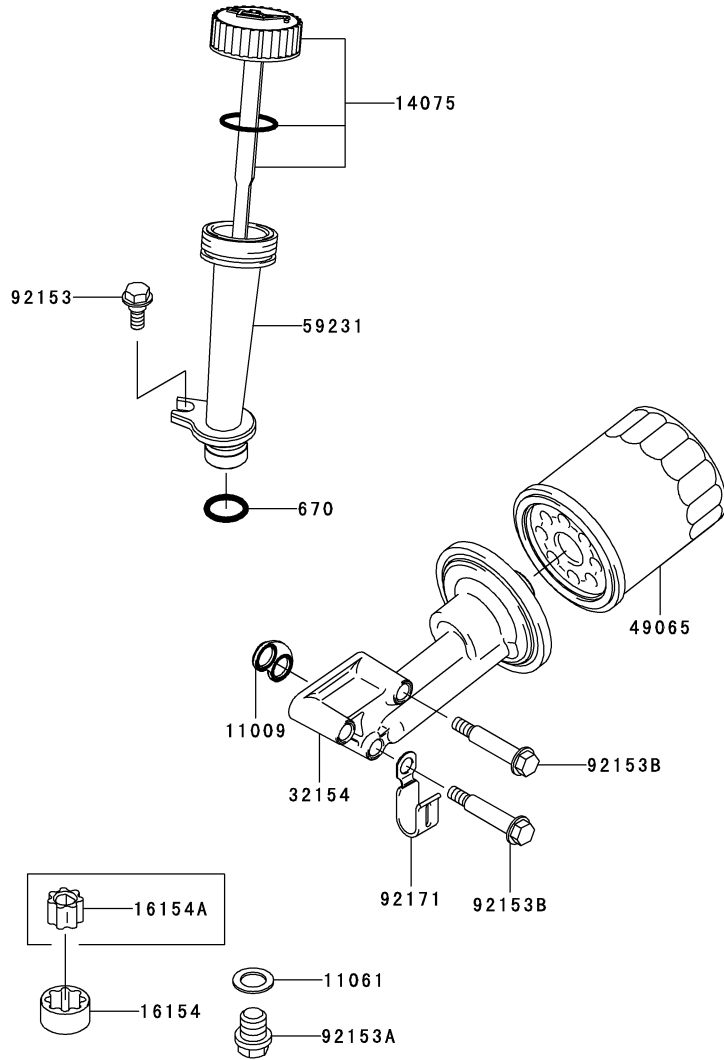

Ref. No.	Part No.	Description	Quantity
11009	11009-2860	GASKET	1
11061	11061-7030	GASKET,12X19X1.27	1
14075	14075-7007	CAP-ASSY	1
16154	16154-7002	ROTOR-PUMP	1
16154A	16154-7004	ROTOR-PUMP	*
32154	32154-7007	PIPE	1
49065	49065-2078	FILTER-OIL	1
59231	59231-7004	FILLER	1
92153	92153-7007	BOLT	1
92153A	92153-7016	BOLT,12X12	1
92153B	92153-7028	BOLT	3
92171	92171-7008	CLAMP	1
670	670D2016	O RING,16MM	1

This catalog covers:

FJ180V- □ S19

GRID NO.

B-07

This grid covers:

COOLING-EQUIPMENT

E0150-A643A

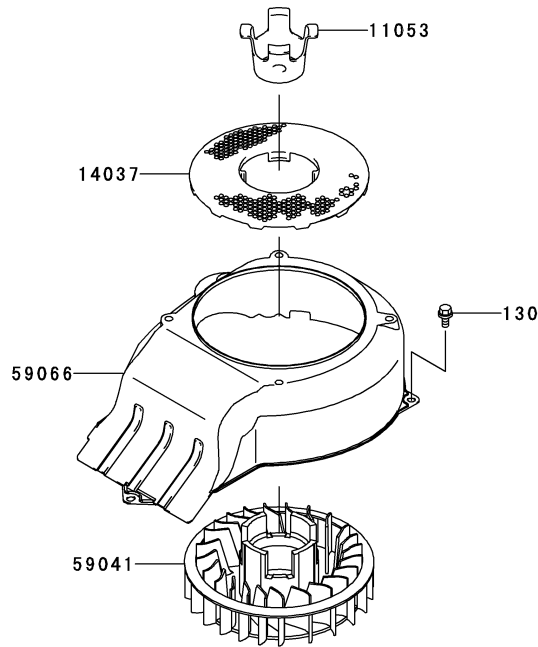
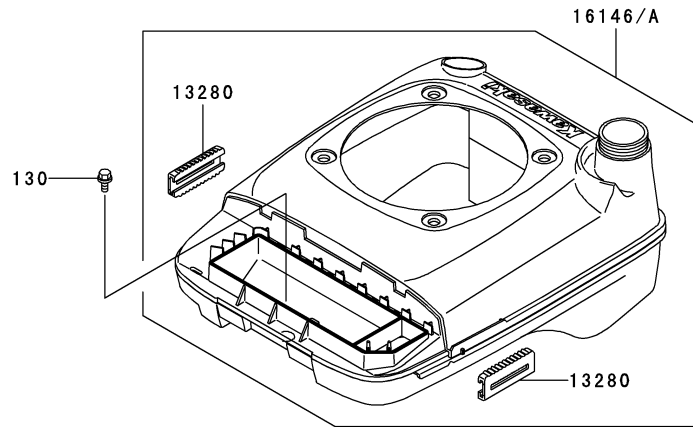

Ref. No.	Part No.	Description	Quantity
11053	11053-7009	BRACKET,FAN	1
13280	13280-7001	HOLDER	2
14037	14037-7017	SCREEN	1
16146	16146-7012	COVER-ASSY	*
16146A	16146-7018	COVER-ASSY	1
59041	59041-7009	FAN	1
59066	59066-7016	HOUSING-FAN	1
130	130B0612	BOLT-FLANGED	2

This catalog covers:

FJ180V- □ S19

GRID NO.

B-08

This grid covers:

ELECTRIC-EQUIPMENT

E0160-B037A

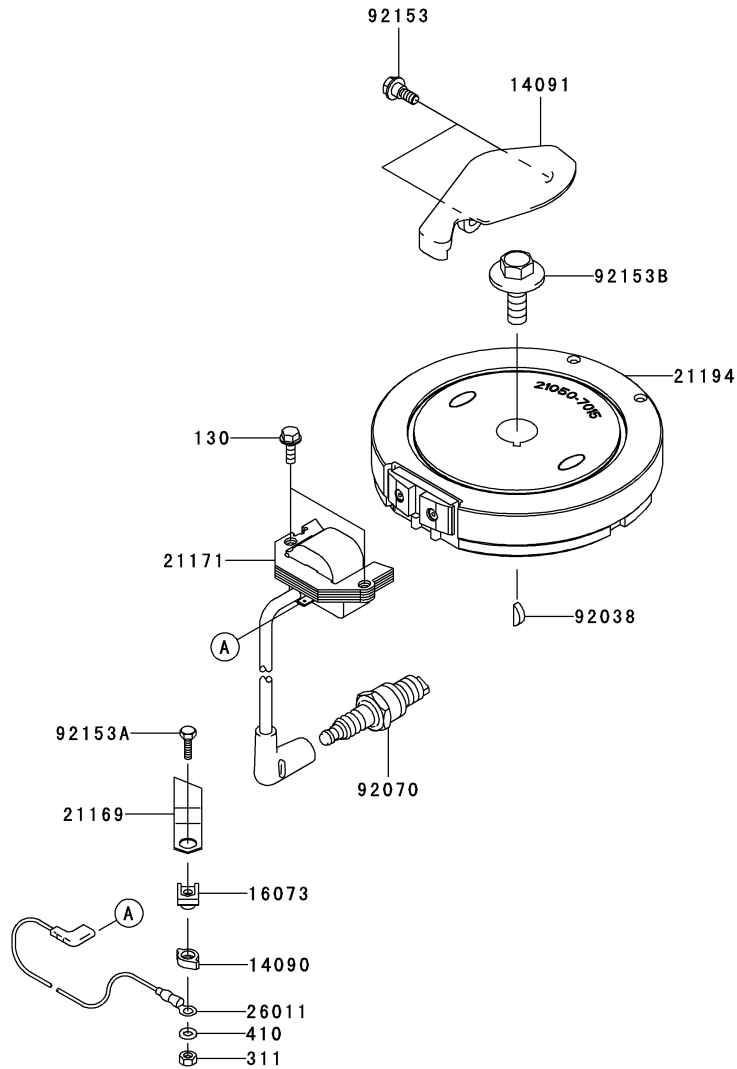

Ref. No.	Part No.	Description	Quantity
			A
14090	14090-2108	COVER	1
14091	14091-7036	COVER	1
16073	16073-2192	INSULATOR	1
21169	21169-2071	TERMINAL	1
21171	21171-7021	COIL-ASSY-IGNITION	1
21194	21194-7024	FLYWHEEL-COMP	1
26011	26011-7013	WIRE-LEAD	1
92038	92038-2077	KEY	1
92070	92070-2088	PLUG-SPARK,BPR5ES(NGK),SOLID	1
92153	92153-7007	BOLT	2
92153A	92153-7012	BOLT,4X16	1
92153B	92153-7030	BOLT,12X30	1
130	130B0620	BOLT-FLANGED	2
311	311B0400	NUT-HEX	1
410	410B0400	W-PLAIN-S	1

This catalog covers:

FJ180V- □ S19

GRID NO.

B-09

This grid covers:

CONTROL-EQUIPMENT

E0170-A456B

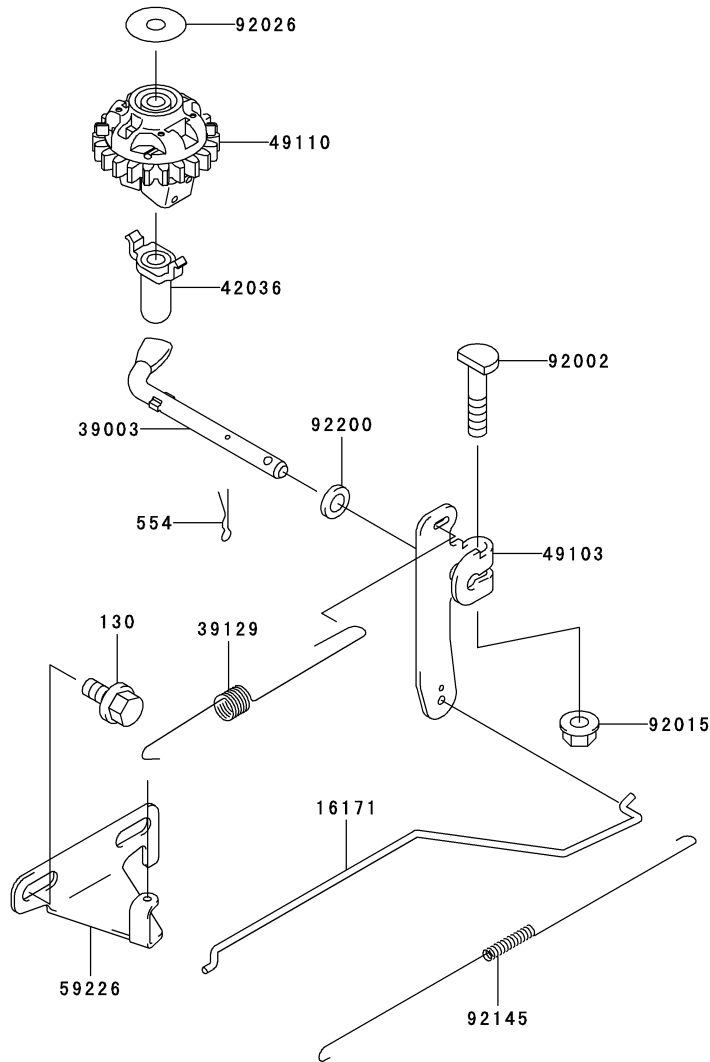

Ref. No.	Part No.	Description	Quantity
16171	16171-7015	LINK, THROTTLE	1
39003	39003-7002	ARM-PIVOT	1
39129	39129-7007	SPRING-GOVERNOR	1
42036	42036-2051	SLEEVE	1
49103	49103-7005	ARM-GOVERNOR	1
49110	49110-7002	GOVERNOR-ASSY	1
59226	59226-7014	PANEL-CONTROL	1
92002	92002-2269	BOLT	1
92015	92015-1193	NUT	1
92026	92200-2036	SPACER	1
92145	92145-7025	SPRING, THROTTLE	1
92200	92200-2029	WASHER, 6.5X11.5X2.0	1
130	130B0612	BOLT-FLANGED	2
554	554A0600	PIN-SNAP	1

This catalog covers:
FJ180V- □ S19

GRID NO. This grid covers:
B-10 CARBURETOR

E0180-A583B

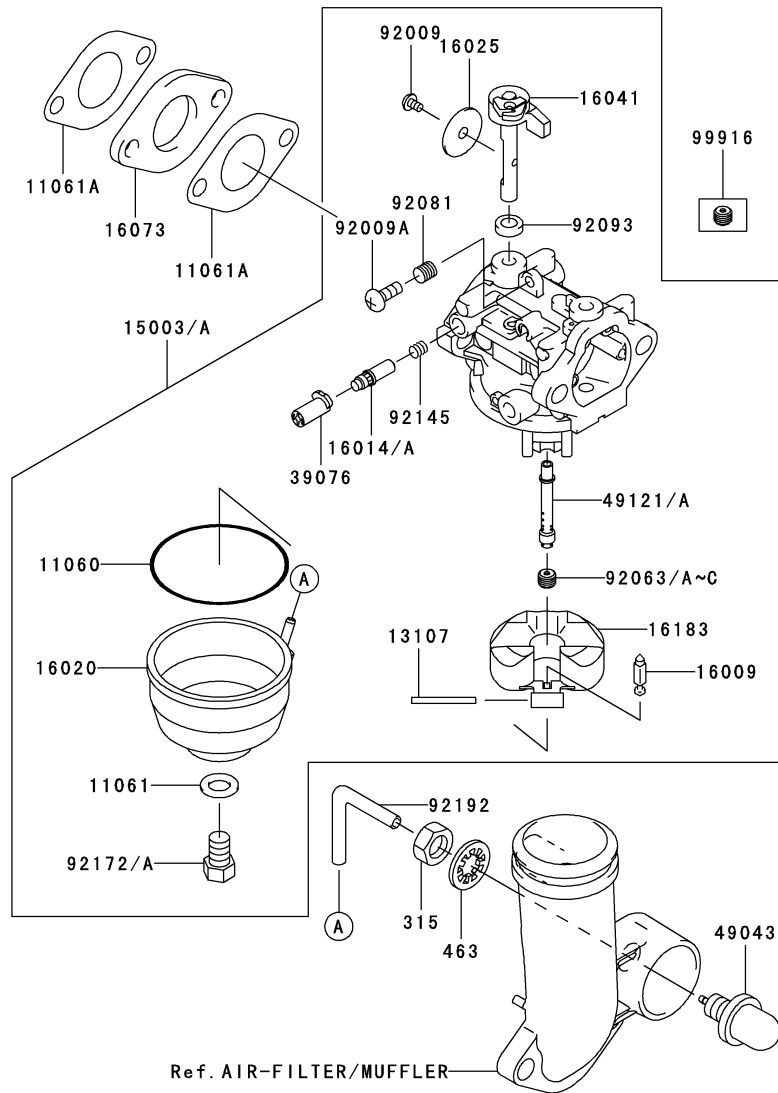

Ref. No.	Part No.	Description	Quantity
11060	11060-2190	GASKET	1
11061	11061-7010	GASKET,SCREW	1
11061A	11061-7015	GASKET,INSULATOR	2
13107	13107-7024	SHAFT	1
15003	15003-7099	CARBURETOR-ASSY	*
15003A	15003-7127	CARBURETOR-ASSY	1
16009	16009-2136	NEEDLE-JET	1
16014	16014-7006	SCREW-PILOT AIR	*
16014A	16014-7008	SCREW-PILOT AIR	1
16020	16020-7005	CHAMBER-FLOAT	1
16025	16025-7007	VALVE-THROTTLE	1
16041	16041-7019	SHAFT-CARBURETOR	1
16073	16073-7006	INSULATOR	1
16183	16183-2002	FLOAT-ASSY	1
39076	39076-7001	LIMITER	1
49043	49043-7002	PUMP-PRIMING	1
49121	49121-7006	NOZZLE-MAIN	*
49121A	49121-7012	NOZZLE-MAIN	1
92009	92009-2083	SCREW	1
92009A	92009-2349	SCREW	1
92063	92063-7048	JET-MAIN,#76	AR
92063A	92063-7048	JET-MAIN,#76	*
92063B	92063-7049	JET-MAIN,#74	AR
92063C	92063-7061	JET-MAIN,#78	1
92081	92081-2234	SPRING	1
92093	92093-2100	SEAL	1
92145	92145-7015	SPRING	1
92172	92172-7003	SCREW	*
92172A	92172-7023	SCREW	1
92192	92192-7002	TUBE,2X5X65	1
99916	99916-7006	KIT-KHI PARTS,JET-MAIN	AR
315	315B1000	NUT-HEX-FINE	1
463	463H1000	WASHER-TOOTHED	1

This catalog covers:

FJ180V- □ S19

GRID NO.

B-11

This grid covers:

AIR-FILTER/MUFFLER

E0190-A751B

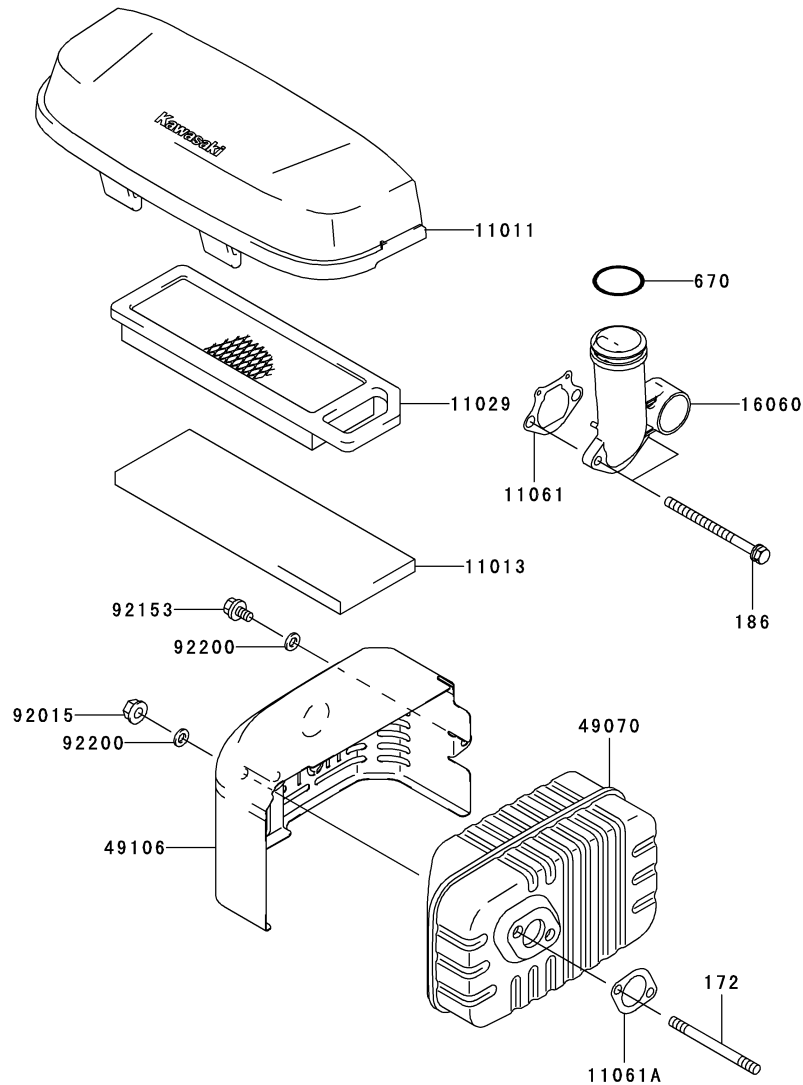

Ref. No.	Part No.	Description	Quantity
11011	11011-7024	CASE-AIR FILTER	1
11013	11013-7032	ELEMENT-AIR FILTER	1
11029	11029-7010	ELEMENT-ASSY-AIR FILTER	1
11061	11061-7012	GASKET,PIPE INTAKE	1
11061A	11061-7029	GASKET,MUFFLER	1
16060	16060-7012	PIPE-INTAKE	1
49070	49070-7019	MUFFLER-COMP	1
49106	49106-7011	COVER-MUFFLER	1
92015	92015-1193	NUT	2
92153	92153-7023	BOLT	1
92200	92200-7022	WASHER,6.4X12X1.6	3
172	172G0680	BOLT-STUD	2
186	186B0680	BOLT-UPSET-WP	2
670	670B3032	O RING,32MM	1

This catalog covers:

FJ180V- □ S19

GRID NO.

C-03

This grid covers:

FUEL-TANK/FUEL-VALVE

E0200-A445D

Ref. No.	Part No.	Description	Quantity
11061	11061-7036	GASKET	1
51023	51023-7001	TAP-ASSY	1
51049	51049-7002	CAP-TANK	1
92170	92170-2088	CLAMP	2
92192	92192-7007	TUBE	1
92192A	92192-7016	TUBE,6.35X12.7X305	1

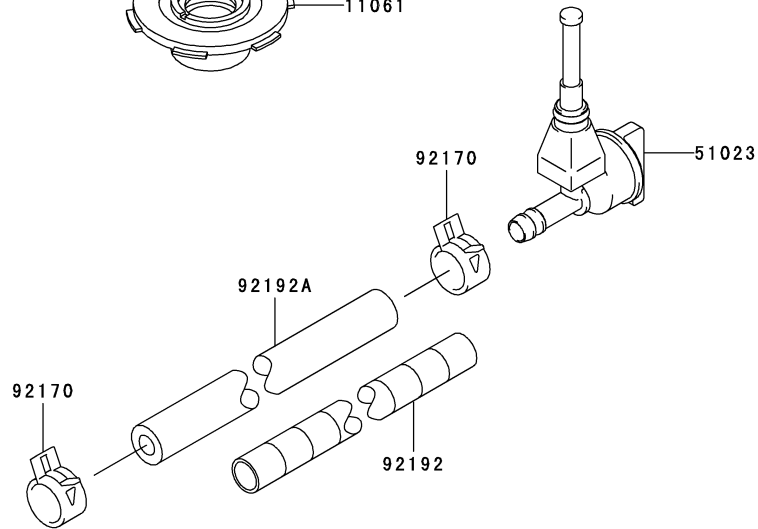
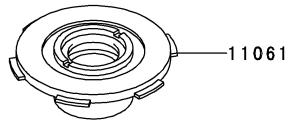
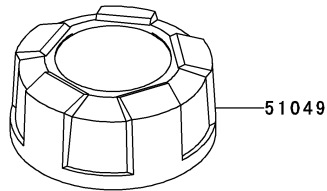

This catalog covers:
FJ180V- □ S19

GRID NO. This grid covers:
C-04 STARTER

E0210-A279B

Ref. No.	Part No.	Description	Quantity
46075	46075-7002	GRIP	1
49088	49088-7021	STARTER-RECOIL	*
49088A	49088-7023	STARTER-RECOIL	1
59106	59106-7003	ROPE,2200MM	1
92153	92153-7021	BOLT,M6	4

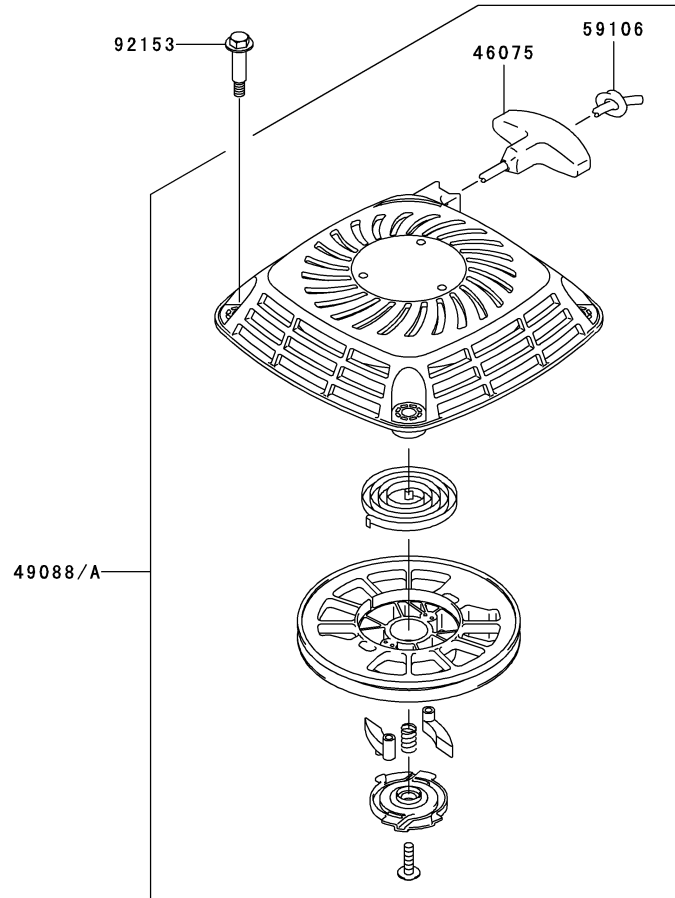

This catalog covers:

FJ180V- □ S19

GRID NO.

D-03

This grid covers:

BRAKE/COVER

F0220-A013A

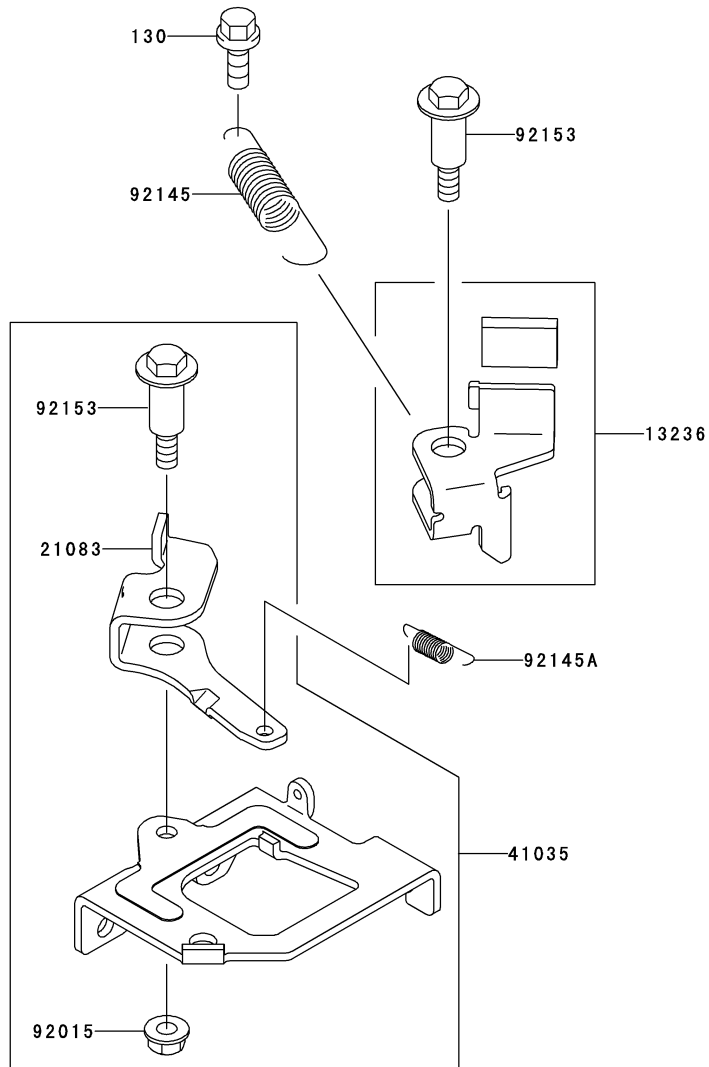

Ref. No.	Part No.	Description	Quantity
			A
13236	13236-7008	LEVER-COMP	1
21083	21083-7016	ARM	1
41035	41035-7005	PANEL-ASSY-BRAKE	1
92015	92015-1193	NUT	1
92145	92145-7023	SPRING	1
92145A	92145-7032	SPRING	1
92153	92153-7020	BOLT	2
130	130B0612	BOLT-FLANGED	1

This catalog covers:
FJ180V- □ S19

GRID NO. This grid covers:
D-04 LABEL

F0290-B072A

Ref. No.	Part No.	Description	Quantity
56070	56070-2021	LABEL-WARNING	1
56080	56080-7019	LABEL-BRAND	1

56070



56080



This catalog covers:

FJ180V- □ S19

GRID NO.

H-09

This grid covers:

PART NAME INDEX

AIR-FILTER/MUFFLER.....	B-11
BRAKE/COVER.....	D-03
CARBURETOR.....	B-10
CONTROL-EQUIPMENT.....	B-09
COOLING-EQUIPMENT.....	B-07
CYLINDER/CRANKCASE.....	B-03
ELECTRIC-EQUIPMENT.....	B-08
FUEL-TANK/FUEL-VALVE.....	C-03
LABEL.....	D-04
LUBRICATION-EQUIPMENT.....	B-06
PISTON/CRANKSHAFT.....	B-04
STARTER.....	C-04
VALVE/CAMSHAFT.....	B-05

This catalog covers:

FJ180V- □ S19

GRID NO.

H-10

This grid covers:

NUMERICAL PARTS INDEX

Part No.	Grid No.	Part No.	Grid No.	Part No.	Grid No.	Part No.	Grid No.	Part No.	Grid No.
11004-7020.....	B-03	16060-7012.....	B-11	92015-1193.....	B-09				
11008-7025.....	B-03	16073-2192.....	B-08	92015-1193.....	B-11				
11009-2860.....	B-06	16073-7006.....	B-10	92015-1193.....	D-03				
11011-7024.....	B-11	16126-7014.....	B-03	92015-2253.....	B-05				
11013-7032.....	B-11	16146-7012.....	B-07	92033-7005.....	B-04				
11022-7005.....	B-03	16146-7018.....	B-07	92038-2077.....	B-08				
11029-7010.....	B-11	16154-7002.....	B-06	92043-7001.....	B-03				
11053-7009.....	B-07	16154-7004.....	B-05	92043-7006.....	B-05				
11060-2190.....	B-10	16154-7004.....	B-06	92049-7008.....	B-03				
11061-7010.....	B-10	16171-7015.....	B-09	92063-7048.....	B-10				
11061-7012.....	B-11	16183-2002.....	B-10	92063-7048.....	B-10				
11061-7015.....	B-10	172G0680.....	B-11	92063-7049.....	B-10				
11061-7020.....	B-03	186B0680.....	B-11	92063-7061.....	B-10				
11061-7023.....	B-03	21083-7009.....	B-05	92070-2088.....	B-08				
11061-7029.....	B-11	21083-7016.....	D-03	92081-2234.....	B-10				
11061-7030.....	B-06	21169-2071.....	B-08	92093-2100.....	B-10				
11061-7031.....	B-03	21171-7021.....	B-08	92145-7015.....	B-10				
11061-7036.....	C-03	21194-7024.....	B-08	92145-7016.....	B-05				
12004-7005.....	B-05	214B0510.....	B-03	92145-7023.....	D-03				
12005-7006.....	B-05	26011-7013.....	B-08	92145-7025.....	B-09				
12009-7001.....	B-05	311B0400.....	B-08	92145-7032.....	D-03				
12011-2056.....	B-05	315B1000.....	B-10	92153-7007.....	B-06				
12016-7001.....	B-05	32154-7007.....	B-06	92153-7007.....	B-08				
12032-7001.....	B-05	39003-7002.....	B-09	92153-7012.....	B-08				
12043-7004.....	B-05	39076-7001.....	B-10	92153-7016.....	B-06				
12043-7005.....	B-05	39129-7007.....	B-09	92153-7019.....	B-05				
13001-7009.....	B-04	41035-7005.....	D-03	92153-7020.....	D-03				
13002-7001.....	B-04	410B0400.....	B-08	92153-7021.....	C-04				
13008-7001.....	B-04	42036-2051.....	B-09	92153-7023.....	B-11				
13031-7065.....	B-04	46075-7002.....	C-04	92153-7028.....	B-06				
13042-7006.....	B-05	463H1000.....	B-10	92153-7030.....	B-08				
13070-7009.....	B-05	49043-7002.....	B-10	92170-2088.....	C-03				
130B0612.....	B-03	49065-2078.....	B-06	92171-7008.....	B-06				
130B0612.....	B-07	49070-7019.....	B-11	92172-7003.....	B-10				
130B0612.....	B-09	49078-7001.....	B-05	92172-7023.....	B-10				
130B0612.....	D-03	49088-7021.....	C-04	92191-7025.....	B-03				
130B0620.....	B-08	49088-7023.....	C-04	92192-7002.....	B-10				
130G0625.....	B-03	49103-7005.....	B-09	92192-7007.....	C-03				
130G0630.....	B-04	49106-7011.....	B-11	92192-7016.....	C-03				
130G0635.....	B-03	49110-7002.....	B-09	92200-2029.....	B-09				
130T0840.....	B-03	49120-7046.....	B-03	92200-2036.....	B-09				
13107-7024.....	B-10	49121-7006.....	B-10	92200-7022.....	B-11				
13116-7003.....	B-05	49121-7012.....	B-10	99916-7006.....	B-10				
13236-7008.....	D-03	51023-7001.....	C-03						
13251-7011.....	B-04	51049-7002.....	C-03						
13280-7001.....	B-07	551A0612.....	B-03						
14037-7017.....	B-07	554A0600.....	B-09						
14041-7002.....	B-03	56070-2021.....	D-04						
14075-7007.....	B-06	56080-7019.....	D-04						
14090-2108.....	B-08	59041-7009.....	B-07						
14091-7010.....	B-03	59066-7016.....	B-07						
14091-7036.....	B-08	59106-7003.....	C-04						
15003-7099.....	B-10	59226-7014.....	B-09						
15003-7127.....	B-10	59231-7004.....	B-06						
16009-2136.....	B-10	670B3032.....	B-11						
16014-7006.....	B-10	670D2016.....	B-06						
16014-7008.....	B-10	92002-2269.....	B-09						
16020-7005.....	B-10	92009-2083.....	B-10						
16025-7007.....	B-10	92009-2341.....	B-05						
16041-7019.....	B-10	92009-2349.....	B-10						