

This catalog covers:
FJ180V-□G80

This fig. covers:
TITLE

PARTS CATALOG

4-STROKE ENGINE

FJ180V

| PRODUCT CODE | NOTE |
|--------------|-------|
| FJ180V-BG80 | MOWER |
| | |
| | |
| | |
| | |
| | |

PARTS CATALOG INTRODUCTION

This parts catalog lists parts and sub-assemblies provided as service parts.

When it becomes necessary to replace parts, always use KAWASAKI GENUINE PARTS which have passed strict inspection which guarantees quality and performance.

1. HOW TO ORDER PARTS

- When ordering the parts, be sure to use the parts catalog corresponding to the product code. Check the product revision codes on the product and the catalog.
 Product Code (example) : FA130D-AA00
└──────────────────┘
Product Revision Code
- Specify the part code (all digits) exactly as listed in this catalog on your parts order.
- The parts not shown in the illustrations of this catalog are not sold separately; only the complete units or next higher assemblies illustrated are supplied as the service parts.

2. EXPLANATION OF PARTS CATALOG FORMAT

This catalog covers: **TH026D-□A10** (1)

This fig. covers: **01 CYLINDER/CRANKCASE** (2) (5) (7)

| Ref. No. | Part No. | Description | Quantity |
|----------|------------|---------------------|----------|
| 11005 | 11005-2137 | CYLINDER-ENGINE | 1 |
| 11060 | 11060-2402 | GASKET,CYLINDER | 1 |
| 11065 | 11065-2264 | CAP | 2 |
| 14002 | 14002-2267 | CRANKCASE | 1 |
| 14002A | 14002-2328 | CRANKCASE | 1 |
| 34001 | 34001-2063 | STAND | 1 |
| 92009 | 92009-2115 | SCREW | 3 |
| 92043 | 92043-1392 | PIN | 2 |
| 92045 | 92045-2006 | BEARING-BALL,6000C3 | 2 |
| 92049 | 92049-2074 | SEAL-OIL | 2 |
| 92150 | 92150-2091 | BOLT | 4 |

1 JUN.03.1999 E0110-A216A

1) Product Code

This code describes the product code covered by this catalog. The product revision code, which is a part of the product code, is omitted.

2) Part Group Title

This title is the representative name for the group of parts illustrated on the page.

3) Reference Number

The reference numbers are shown on the illustration and the list as the link between them.

PARTS LIST INFORMATION

4) Part Number

This is the key of your parts ordering.

Three kinds of part number are used in this catalog.

a. Structure 1

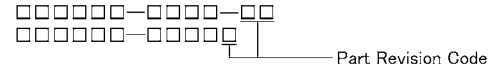

b. Structure 2

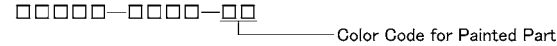

c. Standard Hardware Number

(for bolts, nuts, washer, or the like)

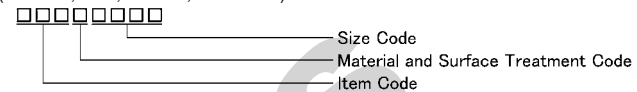

5) Description and Additional Information

The part name, the location, the size, and the serial number as additional information, etc. are described here. Use them to find out and check the part required.

When a part number is changed without change of the product revision code and the changed parts are not interchangeable, the serial number of the product is noted as follows;

- (- FA130 - 100001) : Affected units are from beginning of the product of the product code up to and including this serial number.
- (FA130 - 100002 -) : Affected units are from this serial number and above.
- (FA130 - 100002 - FA130 - 110001) : Affected units are in this serial number range.

6) Quantity

The figure shows quantity of the part required at the indicated position on the illustration and for the specified product revision code.

The asterisk (*) on this column means the part can be used as the substitute on the product and is supplied until the stock is exhausted.

Note:Some small parts will be supplied by units.

Example: If six (6) bolts are ordered and the minimum quantity per unit is five (5), two (2), units of the bolt will be delivered.

7) Product Revision Code

This Code indicates an important change which affects the service parts interchangeability.

3. ABBREVIATIONS

| | | |
|--------------------|--------------------------|--------------------------------|
| #.....Number | FR.....Front | RH.....Right Hand |
| &.....And | G.....Gram | RPM.....Revolutions Per Minute |
| (+).....Plus | HEX.....Hexagonal | RR.....Rear |
| (-).....Minus | ID=.....Inside Diameter | STD.....Standard |
| 2ND.....Second | IN.....Inch | T.....Teeth |
| 3RD.....Third | L=.....Length | T=.....Thickness |
| 4TH.....Fourth | LH.....Left Hand | U/S.....Under Size |
| A.....Ampere | LWR.....Lower | UPP.....Upper |
| AR.....As Required | MM.....Millimeter | V.....Volt |
| ASSY.....Assembly | O/S.....Over Size | W.....Watt |
| CNT.....Center | OD=.....Outside Diameter | |
| COMP.....Complete | REF.....Reference | |

This catalog covers:

FJ180V- □ G80

This fig. covers:

01 CYLINDER/CRANKCASE

E0110-A560B

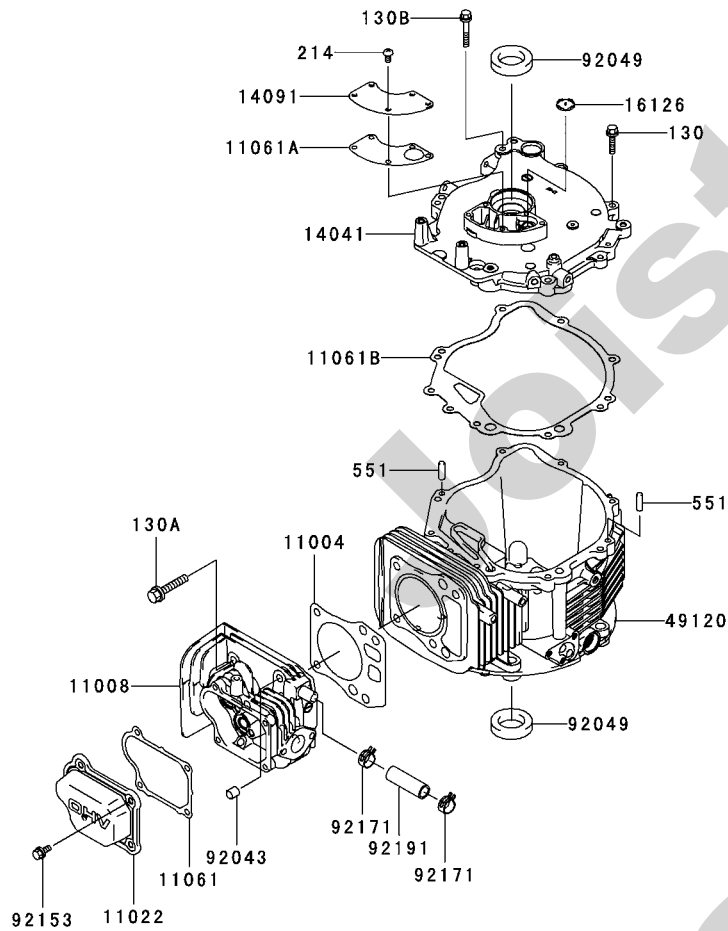

| Ref. No. | Part No. | Description | Quantity |
|----------|------------|------------------------|----------|
| 11004 | 11004-7020 | GASKET-HEAD | 1 |
| 11008 | 11008-7025 | HEAD-COMP-CYLINDER | 1 |
| 11022 | 11022-7005 | CASE-ROCKER | 1 |
| 11061 | 11061-7023 | GASKET,CASE ROCKER | 1 |
| 11061A | 11061-7031 | GASKET,BREATHER | 1 |
| 11061B | 11061-7060 | GASKET,COVER-CRANKCASE | 1 |
| 14041 | 14041-7009 | COVER-COMP | 1 |
| 14091 | 14091-7010 | COVER,BREATHER | 1 |
| 16126 | 16126-7014 | VALVE,BREATHER | 1 |
| 49120 | 49120-7094 | CRANKCASE-COMP | 1 |
| 92043 | 92043-7001 | PIN | 2 |
| 92049 | 92049-7008 | SEAL-OIL,28-44-9 TC | 2 |
| 92153 | 92153-7043 | BOLT,6X12 | 4 |
| 92171 | 92171-7024 | CLAMP | 2 |
| 92191 | 92191-7025 | TUBE,12X16X49 | 1 |
| 130 | 130BA0625 | BOLT-FLANGED,6X25 | 7 |
| 130A | 130CA0840 | BOLT-FLANGED,8X40 | 4 |
| 130B | 130G0635 | BOLT-FLANGED,6X35 | 1 |
| 214 | 214AA0510 | SCREW-PAN+-.5X10 | 5 |
| 551 | 551A0612 | PIN-DOWEL,6X12 | 2 |

This catalog covers:
FJ180V- □ G80

This fig. covers:
02 PISTON/CRANKSHAFT

E0120-A368A

| Ref. No. | Part No. | Description | B | Quantity |
|----------|------------|------------------------|----|----------|
| 13001 | 13001-7022 | PISTON-ENGINE | * | |
| 13001A | 13001-7023 | PISTON-ENGINE | 1 | |
| 13002 | 13002-7001 | PIN-PISTON | 1 | |
| 13008 | 13008-7002 | RING-SET-PISTON | 1 | |
| 13025 | 13025-7006 | RING-SET-PISTON L,0.50 | AR | |
| 13029 | 13029-7005 | PISTON-ENGINE L,0.50 | AR | |
| 13031 | 13031-7066 | CRANKSHAFT-COMP | 1 | |
| 13251 | 13251-7011 | ROD-ASSY-CONNECTING | 1 | |
| 92033 | 92033-7002 | RING-SNAP | 2 | |
| 130 | 130BA0630 | BOLT-FLANGED,6X30 | 2 | |

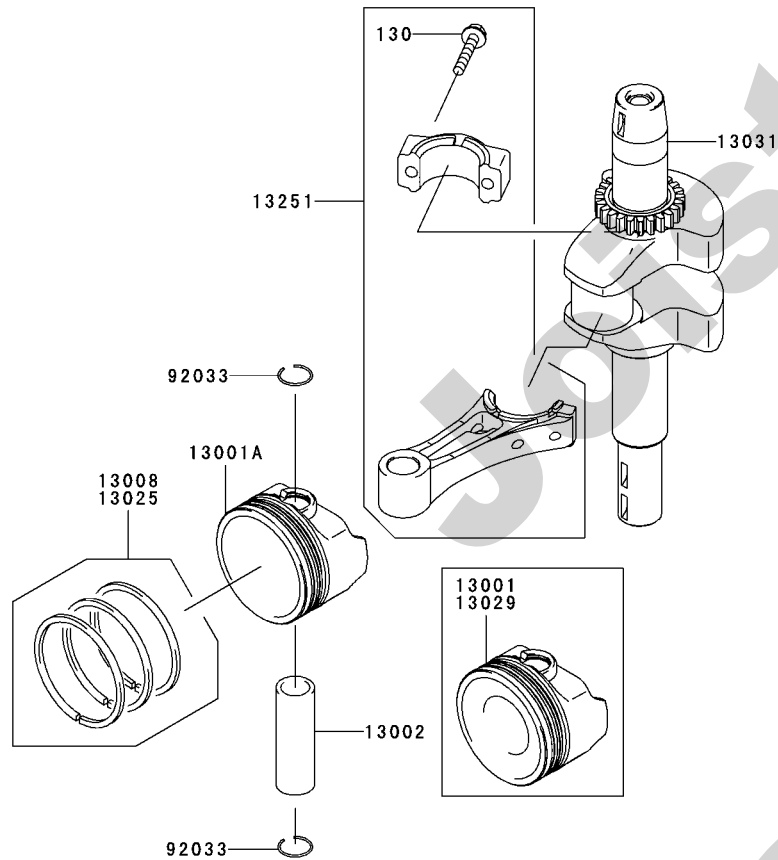

Spareparts Joist

This catalog covers:

FJ180V- □ G80

03

This fig. covers:

VALVE/CAMSHAFT

E0130-A135B

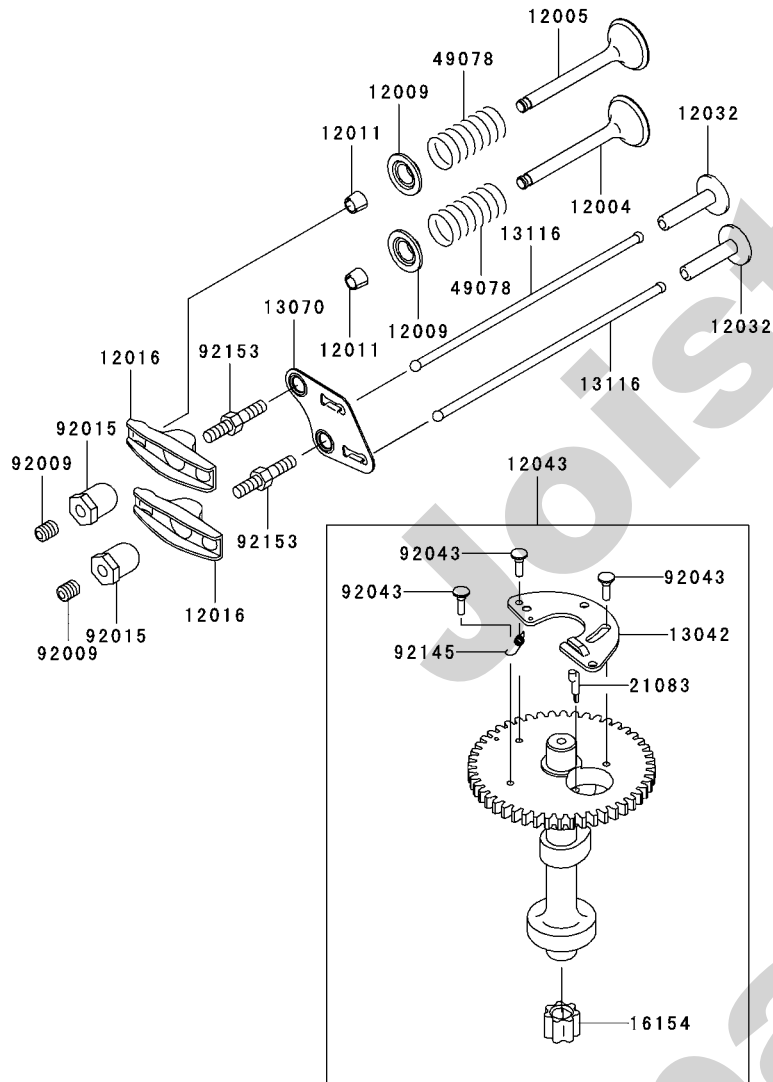

| Ref. No. | Part No. | Description | Quantity |
|----------|------------|-----------------------|----------|
| 12004 | 12004-7005 | VALVE-INTAKE | 1 |
| 12005 | 12005-7006 | VALVE-EXHAUST | 1 |
| 12009 | 12009-7001 | RETAINER-VALVE SPRING | 2 |
| 12011 | 12011-2056 | COLLET | 4 |
| 12016 | 12016-7008 | ARM-ROCKER | 2 |
| 12032 | 12032-7001 | TAPPET | 2 |
| 12043 | 12043-7005 | CAMSHAFT-ASSY-VALVE | 1 |
| 13042 | 13042-7006 | WEIGHT | 1 |
| 13070 | 13070-7009 | GUIDE | 1 |
| 13116 | 13116-7003 | ROD-PUSH | 2 |
| 16154 | 16154-7004 | ROTOR-PUMP | 1 |
| 21083 | 21083-7009 | ARM | 1 |
| 49078 | 49078-7001 | SPRING-ENGINE VALVE | 2 |
| 92009 | 92009-2341 | SCREW | 2 |
| 92015 | 92015-2253 | NUT | 2 |
| 92043 | 92043-7006 | PIN | 3 |
| 92145 | 92145-7016 | SPRING | 1 |
| 92153 | 92153-7019 | BOLT | 2 |

This catalog covers:
FJ180V- □ G80

This fig. covers:
04 LUBRICATION-EQUIPMENT

E0140-A411A

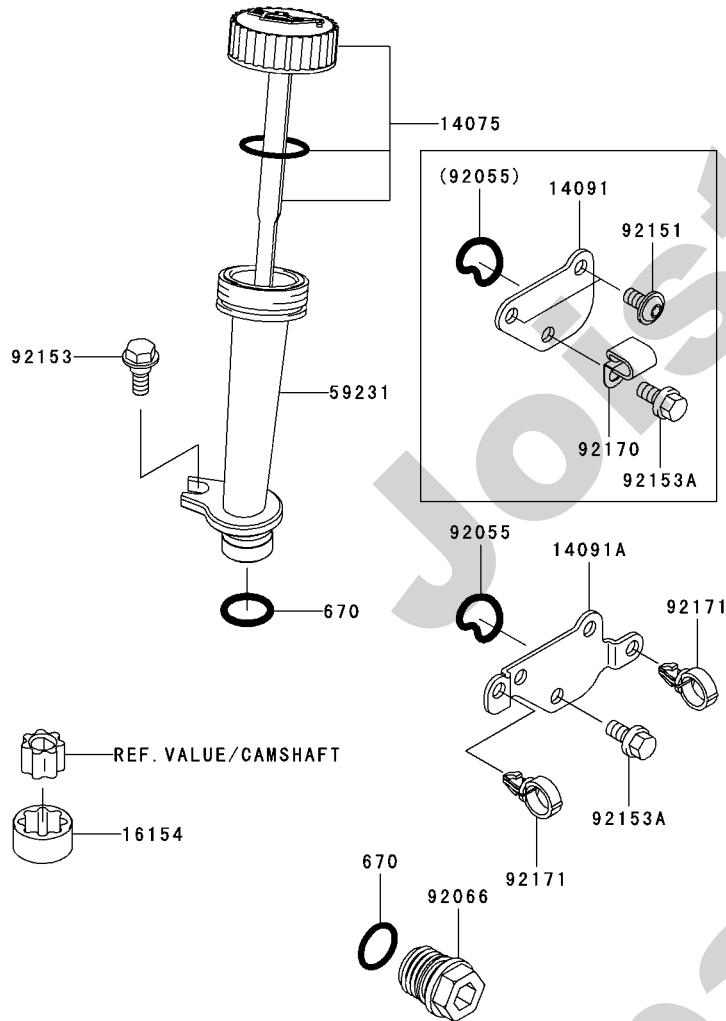

| Ref. No. | Part No. | Description | Quantity |
|----------|------------|------------------|----------|
| 14075 | 14075-7007 | CAP-ASSY | 1 |
| 14091 | 14091-7011 | COVER,OIL FILTER | * |
| 14091A | 14091-7061 | COVER,OIL FILTER | 1 |
| 16154 | 16154-7002 | ROTOR-PUMP | 1 |
| 59231 | 59231-7004 | FILLER | 1 |
| 92055 | 92055-2151 | RING-O | 1 |
| 92066 | 92066-7003 | PLUG | 1 |
| 92151 | 92151-7012 | BOLT,6X12 | * |
| 92153 | 92153-7007 | BOLT | 1 |
| 92153A | 92153-7043 | BOLT,6X12 | 3 |
| 92170 | 92170-1577 | CLAMP | * |
| 92171 | 92171-7014 | CLAMP | 2 |
| 670 | 670D2016 | O RING,16MM | 2 |

This catalog covers:

FJ180V- □ G80

05

This fig. covers:

COOLING-EQUIPMENT

E0150-A643E

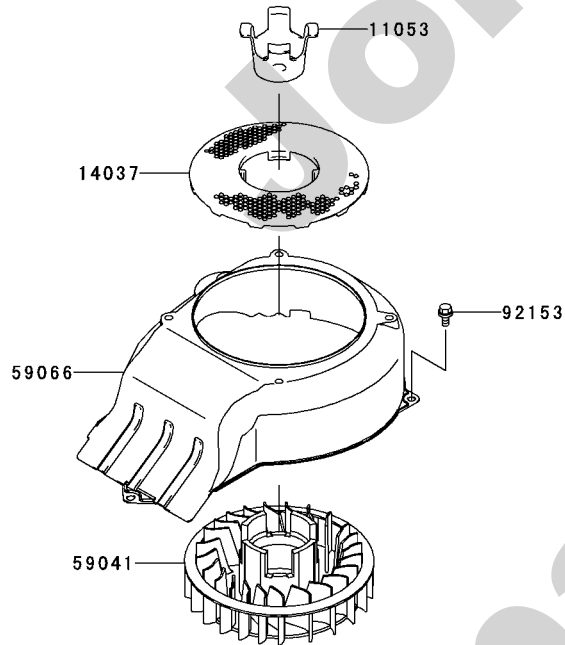
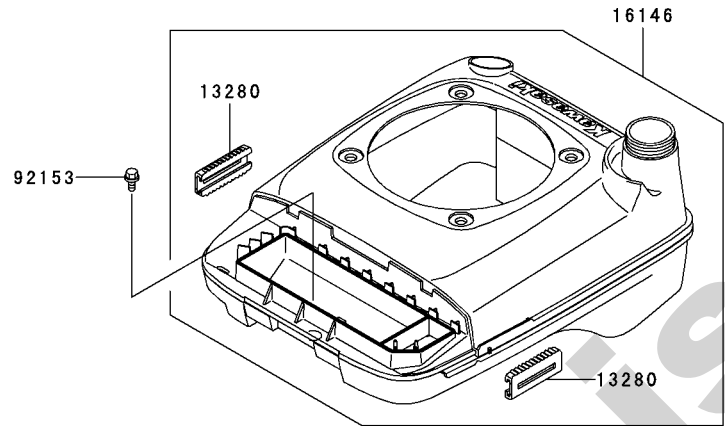

| Ref. No. | Part No. | Description | Quantity |
|----------|------------|-------------|----------|
| 11053 | 11053-7009 | BRACKET,FAN | 1 |
| 13280 | 13280-7001 | HOLDER | 2 |
| 14037 | 14037-7017 | SCREEN | 1 |
| 16146 | 16146-7018 | COVER-ASSY | 1 |
| 59041 | 59041-7009 | FAN | 1 |
| 59066 | 59066-7016 | HOUSING-FAN | 1 |
| 92153 | 92153-7043 | BOLT,6X12 | 2 |

Spareparts Joist

This catalog covers:

FJ180V- □ G80

This fig. covers:

06 ELECTRIC-EQUIPMENT

E0160-B037A

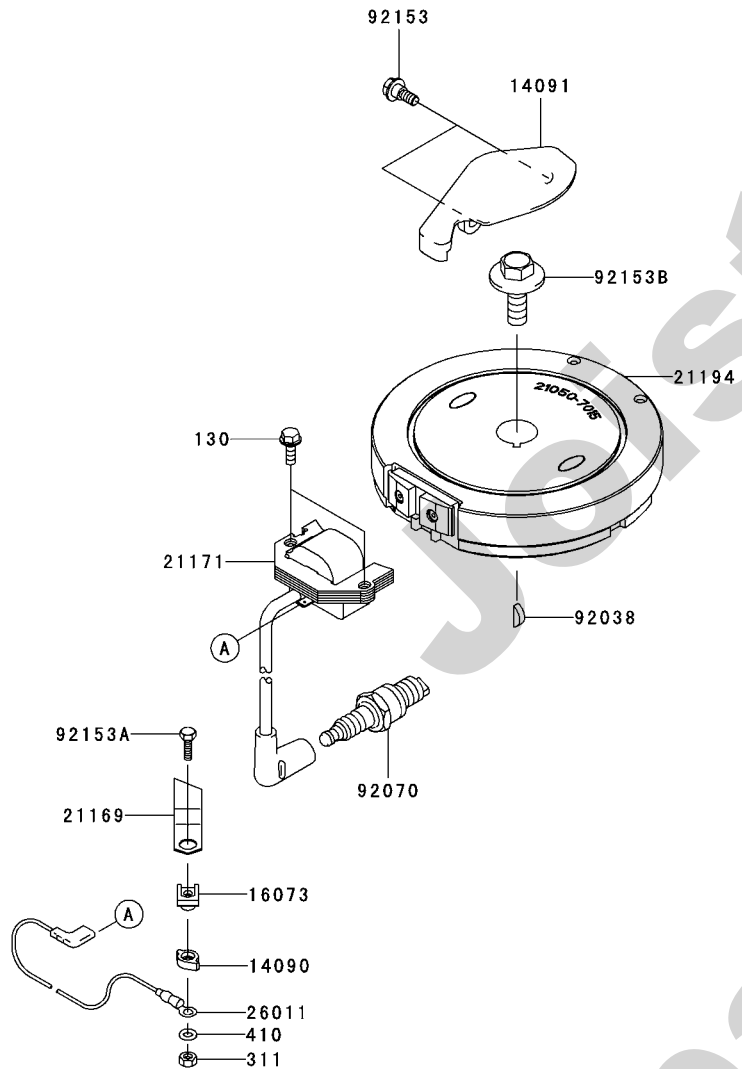

| Ref. No. | Part No. | Description | B | Quantity |
|----------|------------|------------------------------|---|----------|
| 14090 | 14090-2108 | COVER | 1 | |
| 14091 | 14091-7036 | COVER | 1 | |
| 16073 | 16073-2192 | INSULATOR | 1 | |
| 21169 | 21169-2071 | TERMINAL | 1 | |
| 21171 | 21171-7030 | COIL-ASSY-IGNITION | 1 | |
| 21194 | 21194-7024 | FLYWHEEL-COMP | 1 | |
| 26011 | 26011-7013 | WIRE-LEAD | 1 | |
| 92038 | 92038-2077 | KEY | 1 | |
| 92070 | 92070-2088 | PLUG-SPARK,BPR5ES(NGK),SOLID | 1 | |
| 92153 | 92153-7007 | BOLT | 2 | |
| 92153A | 92153-7012 | BOLT,4X16 | 1 | |
| 92153B | 92153-7030 | BOLT,12X30 | 1 | |
| 130 | 130AA0620 | BOLT-FLANGED,6X20 | 2 | |
| 311 | 311B0400 | NUT-HEX,4MM | 1 | |
| 410 | 410B0400 | W-PLAIN-S,4MM | 1 | |

This catalog covers:

FJ180V- □ G80

07

This fig. covers:

CONTROL-EQUIPMENT

E0170-A478J

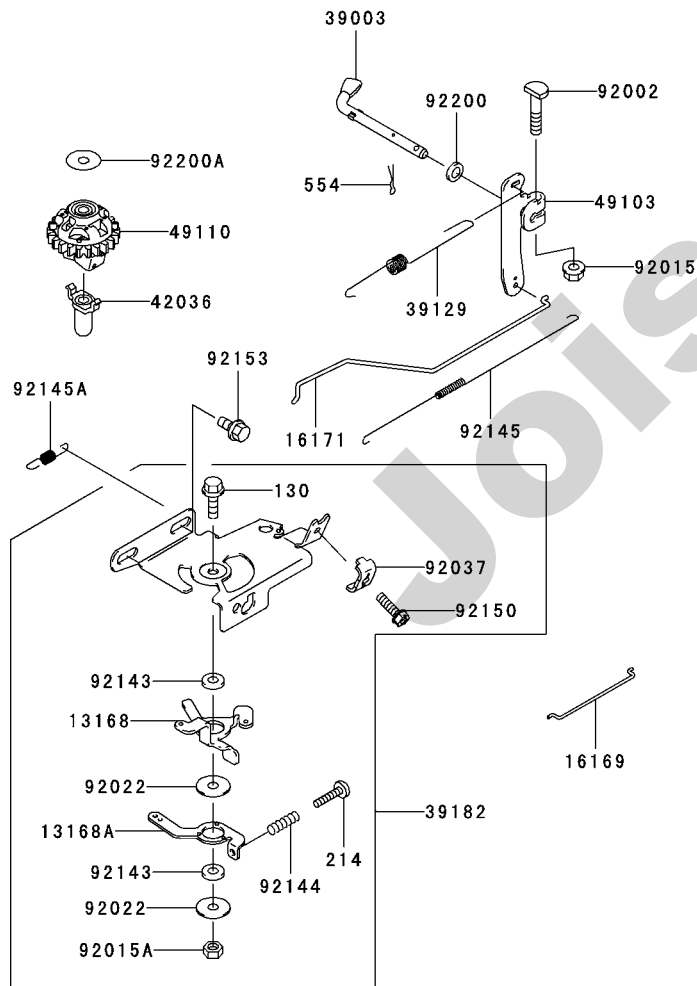

| Ref. No. | Part No. | Description | Quantity |
|----------|------------|----------------------|----------|
| 13168 | 13168-7020 | LEVER | 1 |
| 13168A | 13168-7022 | LEVER | 1 |
| 16169 | 16169-7011 | LINK-CHOKE | 1 |
| 16171 | 16171-7015 | LINK, THROTTLE | 1 |
| 39003 | 39003-7002 | ARM-PIVOT | 1 |
| 39129 | 39129-7014 | SPRING-GOVERNOR | 1 |
| 39182 | 39182-7005 | PANEL-ASSY-CONTROL | 1 |
| 42036 | 42036-2051 | SLEEVE | 1 |
| 49103 | 49103-7005 | ARM-GOVERNOR | 1 |
| 49110 | 49110-7002 | GOVERNOR-ASSY | 1 |
| 92002 | 92002-2269 | BOLT, 6X28 | 1 |
| 92015 | 92015-1193 | NUT | 1 |
| 92015A | 92015-2051 | NUT | 1 |
| 92022 | 92022-2372 | WASHER, 6X19X1.2 | 2 |
| 92037 | 92037-2209 | CLAMP | 1 |
| 92143 | 92143-2135 | COLLAR, 6X13X2.3 | 2 |
| 92144 | 92144-2266 | SPRING | 1 |
| 92145 | 92145-7025 | SPRING, THROTTLE | 1 |
| 92145A | 92145-7032 | SPRING | 1 |
| 92150 | 92150-2182 | BOLT, 5X18 | 1 |
| 92153 | 92153-7043 | BOLT, 6X12 | 2 |
| 92200 | 92200-2029 | WASHER, 6.5X11.5X2.0 | 1 |
| 92200A | 92200-2036 | WASHER, 6.2X20X0.5 | 1 |
| 130 | 130AA0618 | BOLT-FLANGED, 6X18 | 1 |
| 214 | 214AA0420 | SCREW-PAN+-, 4X20 | 1 |
| 554 | 554A0600 | PIN-SNAP, 1.2X21.2 | 1 |

This catalog covers:

FJ180V- □ G80

This fig. covers:

08 CARBURETOR

E0180-A592A

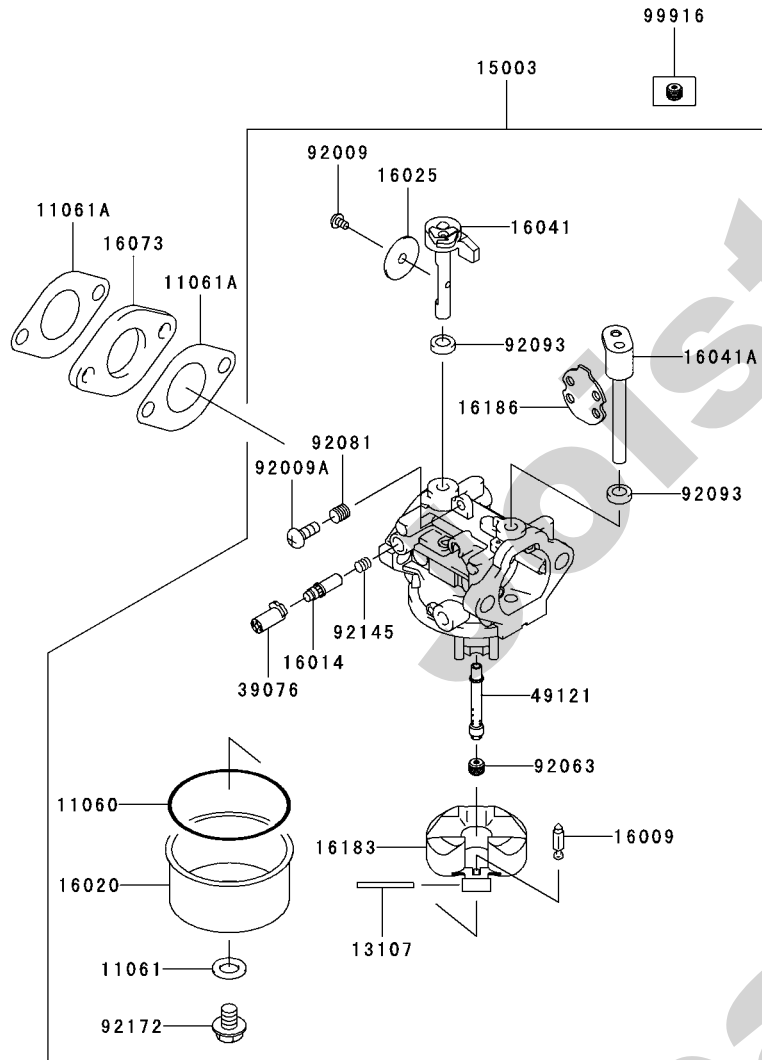

| Ref. No. | Part No. | Description | Quantity |
|----------|------------|----------------------|----------|
| 11060 | 11060-2190 | GASKET | 1 |
| 11061 | 11061-7010 | GASKET,SCREW | 1 |
| 11061A | 11061-7015 | GASKET,INSULATOR | 2 |
| 13107 | 13107-7024 | SHAFT | 1 |
| 15003 | 15003-7132 | CARBURETOR-ASSY | 1 |
| 16009 | 16009-2136 | NEEDLE-JET | 1 |
| 16014 | 16014-7008 | SCREW-PILOT AIR | 1 |
| 16020 | 16020-7004 | CHAMBER-FLOAT | 1 |
| 16025 | 16025-7007 | VALVE-THROTTLE | 1 |
| 16041 | 16041-7019 | SHAFT-CARBURETOR | 1 |
| 16041A | 16041-7020 | SHAFT-CARBURETOR | 1 |
| 16073 | 16073-7006 | INSULATOR | 1 |
| 16183 | 16183-2002 | FLOAT-ASSY | 1 |
| 16186 | 16186-7003 | VALVE-ASSY-CHOKE | 1 |
| 39076 | 39076-7001 | LIMITER | 1 |
| 49121 | 49121-7008 | NOZZLE-MAIN | 1 |
| 92009 | 92009-2083 | SCREW | 1 |
| 92009A | 92009-2349 | SCREW | 1 |
| 92063 | 92063-7049 | JET-MAIN,#74 | 1 |
| 92081 | 92081-2234 | SPRING | 1 |
| 92093 | 92093-2100 | SEAL | 2 |
| 92145 | 92145-7015 | SPRING | 1 |
| 92172 | 92172-7002 | SCREW | 1 |
| 99916 | 99916-7007 | KIT,JET-MAIN,#72,#70 | AR |

This catalog covers:

FJ180V- □ G80

09

This fig. covers:

AIR-FILTER/MUFFLER

E0190-A986A

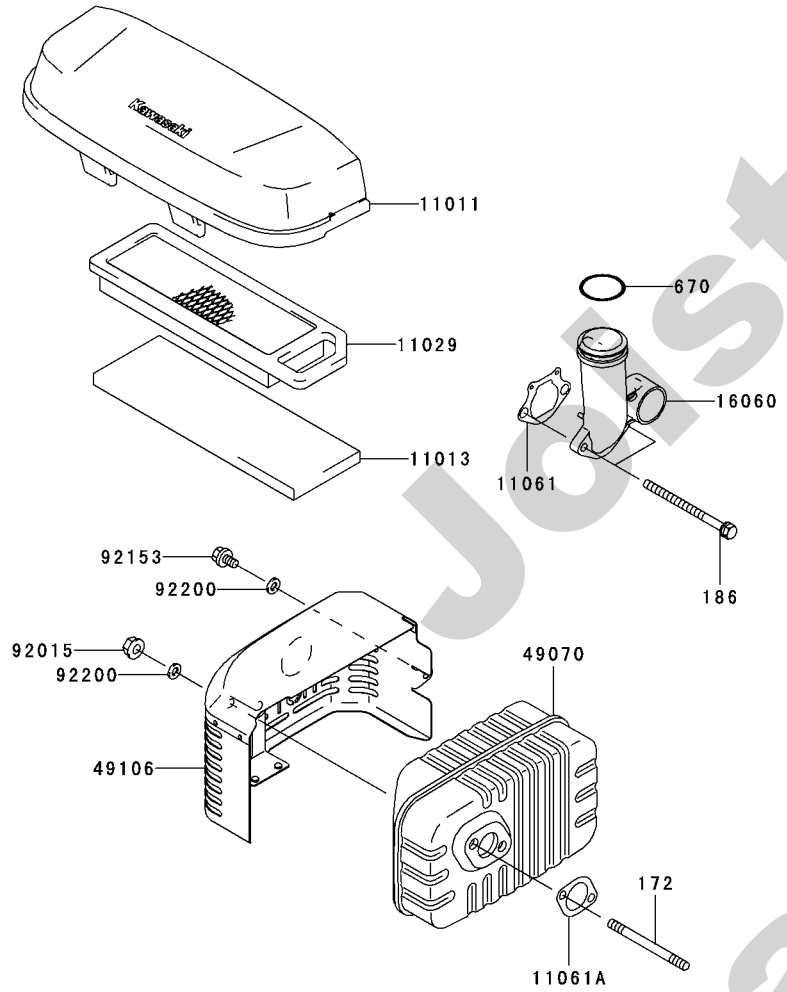

| Ref. No. | Part No. | Description | Quantity |
|----------|------------|-------------------------|----------|
| 11011 | 11011-7025 | CASE-AIR FILTER | 1 |
| 11013 | 11013-7032 | ELEMENT-AIR FILTER | 1 |
| 11029 | 11029-7010 | ELEMENT-ASSY-AIR FILTER | 1 |
| 11061 | 11061-7012 | GASKET,PIPE INTAKE | 1 |
| 11061A | 11061-7029 | GASKET,MUFFLER | 1 |
| 16060 | 16060-7012 | PIPE-INTAKE | 1 |
| 49070 | 49070-7022 | MUFFLER-COMP | 1 |
| 49106 | 49106-7019 | COVER-MUFFLER | 1 |
| 92015 | 92015-1193 | NUT | 2 |
| 92153 | 92153-7023 | BOLT,6X10 | 1 |
| 92200 | 92200-7022 | WASHER,6.4X12X1.6 | 3 |
| 172 | 172BA0680 | BOLT-STUD,6X80 | 2 |
| 186 | 186AA0680 | BOLT-UPSET-WP,6X80 | 2 |
| 670 | 670B3032 | O RING,32MM | 1 |

Spareparts Joist

This catalog covers:
FJ180V- □ G80

This fig. covers:
10 FUEL-TANK/FUEL-VALVE

E0200-A585B

| Ref. No. | Part No. | Description | Quantity |
|----------|------------|--------------------|----------|
| 11060 | 11060-2145 | GASKET | 1 |
| 42036 | 42036-7015 | SLEEVE | 1 |
| 51023 | 51023-7002 | TAP-ASSY | 1 |
| 51049 | 51049-7002 | CAP-TANK | 1 |
| 92170 | 92170-2009 | CLAMP | 2 |
| 92170A | 92170-2088 | CLAMP | * |
| 92192 | 92192-7043 | TUBE,6.35X12.7X255 | * |
| 92192A | 92192-7106 | TUBE,6X12.7X255 | 1 |

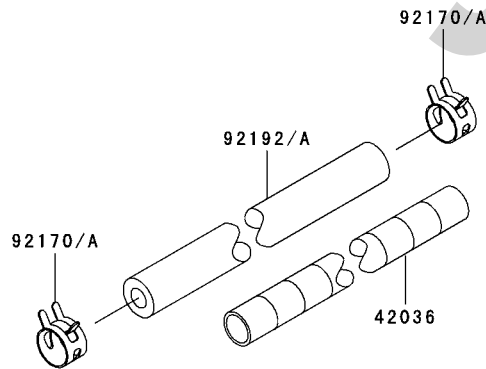
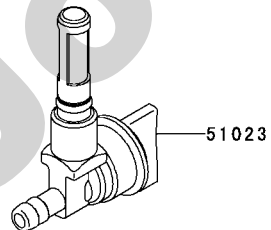
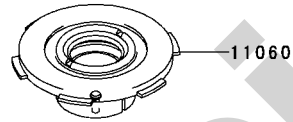
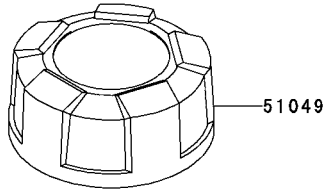

Spareparts Joist

This catalog covers:

FJ180V- □ G80

11

This fig. covers:

STARTER

E0210-A403A

| Ref. No. | Part No. | Description | Quantity |
|----------|------------|----------------|----------|
| 13070 | 13070-7015 | GUIDE | 1 |
| 46075 | 46075-7002 | GRIP | 1 |
| 49088 | 49088-7022 | STARTER-RECOIL | 1 |
| 59106 | 59106-7006 | ROPE,1500MM | 1 |
| 92153 | 92153-7021 | BOLT,M6 | 4 |

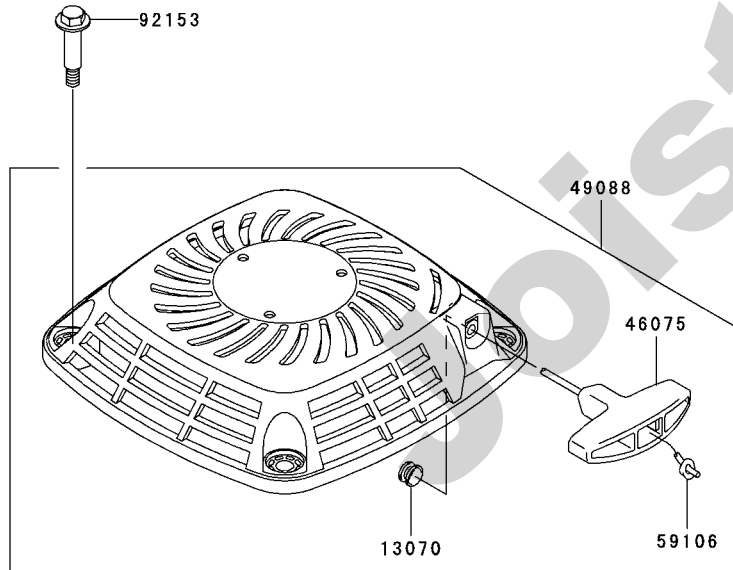

This catalog covers:
FJ180V- □ G80

12

This fig. covers:
LABEL

F0290-B072A

| Ref. No. | Part No. | Description | Quantity |
|----------|------------|---------------|----------|
| 56070 | 56070-2021 | LABEL-WARNING | 1 |
| 56080 | 56080-7019 | LABEL-BRAND | 1 |

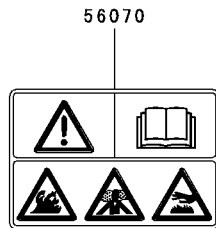

Joist Spareparts Joist

This catalog covers:

FJ180V- □ G80

This fig. covers:

PART NAME INDEX

| | |
|----------------------------|----|
| AIR-FILTER/MUFFLER..... | 09 |
| CARBURETOR..... | 08 |
| CONTROL-EQUIPMENT..... | 07 |
| COOLING-EQUIPMENT..... | 05 |
| CYLINDER/CRANKCASE..... | 01 |
| ELECTRIC-EQUIPMENT..... | 06 |
| FUEL-TANK/FUEL-VALVE..... | 10 |
| LABEL..... | 12 |
| LUBRICATION-EQUIPMENT..... | 04 |
| PISTON/CRANKSHAFT..... | 02 |
| STARTER..... | 11 |
| VALVE/CAMSHAFT..... | 03 |

This catalog covers:

FJ180V- G80

This fig. covers:

NUMERICAL PARTS INDEX

| Part No. | Fig No. | Part No. | Fig No. | Part No. | Fig No. | Part No. | Fig No. | Part No. | Fig No. |
|-----------------|---------|-----------------|---------|-----------------|---------|----------|---------|----------|---------|
| 11004-7020..... | 01 | 16060-7012..... | 09 | 92038-2077..... | 06 | | | | |
| 11008-7025..... | 01 | 16073-2192..... | 06 | 92043-7001..... | 01 | | | | |
| 11011-7025..... | 09 | 16073-7006..... | 08 | 92043-7006..... | 03 | | | | |
| 11013-7032..... | 09 | 16126-7014..... | 01 | 92049-7008..... | 01 | | | | |
| 11022-7005..... | 01 | 16146-7018..... | 05 | 92055-2151..... | 04 | | | | |
| 11029-7010..... | 09 | 16154-7002..... | 04 | 92063-7049..... | 08 | | | | |
| 11053-7009..... | 05 | 16154-7004..... | 03 | 92066-7003..... | 04 | | | | |
| 11060-2145..... | 10 | 16169-7011..... | 07 | 92070-2088..... | 06 | | | | |
| 11060-2190..... | 08 | 16171-7015..... | 07 | 92081-2234..... | 08 | | | | |
| 11061-7010..... | 08 | 16183-2002..... | 08 | 92093-2100..... | 08 | | | | |
| 11061-7012..... | 09 | 16186-7003..... | 08 | 92143-2135..... | 07 | | | | |
| 11061-7015..... | 08 | 172BA0680..... | 09 | 92144-2266..... | 07 | | | | |
| 11061-7023..... | 01 | 186AA0680..... | 09 | 92145-7015..... | 08 | | | | |
| 11061-7029..... | 09 | 21083-7009..... | 03 | 92145-7016..... | 03 | | | | |
| 11061-7031..... | 01 | 21169-2071..... | 06 | 92145-7025..... | 07 | | | | |
| 11061-7060..... | 01 | 21171-7030..... | 06 | 92145-7032..... | 07 | | | | |
| 12004-7005..... | 03 | 21194-7024..... | 06 | 92150-2182..... | 07 | | | | |
| 12005-7006..... | 03 | 214AA0420..... | 07 | 92151-7012..... | 04 | | | | |
| 12009-7001..... | 03 | 214AA0510..... | 01 | 92153-7007..... | 04 | | | | |
| 12011-2056..... | 03 | 26011-7013..... | 06 | 92153-7007..... | 06 | | | | |
| 12016-7008..... | 03 | 311B0400..... | 06 | 92153-7012..... | 06 | | | | |
| 12032-7001..... | 03 | 39003-7002..... | 07 | 92153-7019..... | 03 | | | | |
| 12043-7005..... | 03 | 39076-7001..... | 08 | 92153-7021..... | 11 | | | | |
| 13001-7022..... | 02 | 39129-7014..... | 07 | 92153-7023..... | 09 | | | | |
| 13001-7023..... | 02 | 39182-7005..... | 07 | 92153-7030..... | 06 | | | | |
| 13002-7001..... | 02 | 410B0400..... | 06 | 92153-7043..... | 01 | | | | |
| 13008-7002..... | 02 | 42036-2051..... | 07 | 92153-7043..... | 04 | | | | |
| 13025-7006..... | 02 | 42036-7015..... | 10 | 92153-7043..... | 05 | | | | |
| 13029-7005..... | 02 | 46075-7002..... | 11 | 92153-7043..... | 07 | | | | |
| 13031-7066..... | 02 | 49070-7022..... | 09 | 92170-1577..... | 04 | | | | |
| 13042-7006..... | 03 | 49078-7001..... | 03 | 92170-2009..... | 10 | | | | |
| 13070-7009..... | 03 | 49088-7022..... | 11 | 92170-2088..... | 10 | | | | |
| 13070-7015..... | 11 | 49103-7005..... | 07 | 92171-7014..... | 04 | | | | |
| 130AA0618..... | 07 | 49106-7019..... | 09 | 92171-7024..... | 01 | | | | |
| 130AA0620..... | 06 | 49110-7002..... | 07 | 92172-7002..... | 08 | | | | |
| 130BA0625..... | 01 | 49120-7094..... | 01 | 92191-7025..... | 01 | | | | |
| 130BA0630..... | 02 | 49121-7008..... | 08 | 92192-7043..... | 10 | | | | |
| 130CA0840..... | 01 | 51023-7002..... | 10 | 92192-7106..... | 10 | | | | |
| 130G0635..... | 01 | 51049-7002..... | 10 | 92200-2029..... | 07 | | | | |
| 13107-7024..... | 08 | 551A0612..... | 01 | 92200-2036..... | 07 | | | | |
| 13116-7003..... | 03 | 554A0600..... | 07 | 92200-7022..... | 09 | | | | |
| 13168-7020..... | 07 | 56070-2021..... | 12 | 99916-7007..... | 08 | | | | |
| 13168-7022..... | 07 | 56080-7019..... | 12 | | | | | | |
| 13251-7011..... | 02 | 59041-7009..... | 05 | | | | | | |
| 13280-7001..... | 05 | 59066-7016..... | 05 | | | | | | |
| 14037-7017..... | 05 | 59106-7006..... | 11 | | | | | | |
| 14041-7009..... | 01 | 59231-7004..... | 04 | | | | | | |
| 14075-7007..... | 04 | 670B3032..... | 09 | | | | | | |
| 14090-2108..... | 06 | 670D2016..... | 04 | | | | | | |
| 14091-7010..... | 01 | 92002-2269..... | 07 | | | | | | |
| 14091-7011..... | 04 | 92009-2083..... | 08 | | | | | | |
| 14091-7036..... | 06 | 92009-2341..... | 03 | | | | | | |
| 14091-7061..... | 04 | 92009-2349..... | 08 | | | | | | |
| 15003-7132..... | 08 | 92015-1193..... | 07 | | | | | | |
| 16009-2136..... | 08 | 92015-1193..... | 09 | | | | | | |
| 16014-7008..... | 08 | 92015-2051..... | 07 | | | | | | |
| 16020-7004..... | 08 | 92015-2253..... | 03 | | | | | | |
| 16025-7007..... | 08 | 92022-2372..... | 07 | | | | | | |
| 16041-7019..... | 08 | 92033-7002..... | 02 | | | | | | |
| 16041-7020..... | 08 | 92037-2209..... | 07 | | | | | | |