

This catalog covers:
FJ100D-□S52

GRID NO. This grid covers:
A-01 TITLE

PARTS CATALOG

4-STROKE ENGINE

FJ100D

PRODUCT CODE	NOTE
FJ100D-AS52	

PARTS CATALOG INTRODUCTION

This parts catalog lists parts and sub-assemblies provided as service parts. When it becomes necessary to replace parts, always use KAWASAKI GENUINE PARTS which have passed strict inspection which guarantees quality and performance.

1. HOW TO ORDER PARTS

- When ordering the parts, be sure to use the parts catalog corresponding to the product code. Check the product revision codes on the product and the catalog.
 Product Code (example) : FA130D-AA00
 Product Revision Code
- Specify the part code (all digits) exactly as listed in this catalog on your parts order.
- The parts not shown in the illustrations of this catalog are not sold separately; only the complete units or next higher assemblies illustrated are supplied as the service parts.

2. EXPLANATION OF PARTS CATALOG FORMAT

Ref. No.	Part No.	Description	Quantity	
			A	B
11004	11004-7001	GASKET-HEAD	2	2
11008	11008-7001	HEAD-COMP-CYLINDER#1	1	1
11008A	11008-7002	HEAD-COMP-CYLINDER#2	1	1
11022	11022-7001	CASE-ROCKER	2	2
11060	11060-7001	GASKET,ROCKER CASE	2	2
11060A	11060-7008	GASKET,CRANKCASE COVER	1	1
11060B	11060-7015	GASKET,BREATHER	1	1
13271	13271-7016	PLATE	1	1
13271A	13271-7016	PLATE	1	1
14690	14690-7001	COVER,BREATHER	1	1
49015	49015-6215	COVER-CRANKCASE	1	1
49109	49109-7002	ELEMENT-BREATHER	1	1
49120	49120-6119	CRANKCASE-COMP	1	1
92033	92033-7003	RING-SNAP	2	2
92043	92043-7001	PIN	6	6
92049	92049-7001	SEAL-OIL	4	4
92049A	92049-7002	SEAL-OIL	1	1
92049B	92049-7004	SEAL-OIL	1	1
92049C	92049-7005	SEAL-OIL	1	1
130	130B0612	BOLT-FLANGED	4	4
130A	130B0640	BOLT-FLANGED	4	4
130B	130T0650	BOLT-FLANGED	17	17
130C	130T0875	BOLT-FLANGED	2	2
172	172G0818	BOLT-STUD	4	4

1) Product Code

This code describes the product code covered by this catalog. The product revision code, which is a part of the product code, is omitted.

2) Part Group Title

This title is the representative name for the group of parts illustrated on the page.

3) Reference Number

The reference numbers are shown on the illustration and the list as the link between them.

4) Part Number

This is the key of your parts ordering. Three kinds of part number are used in this catalog.

- Structure 1
 □□□□□□-□□□□□□-□□
 □□□□□□-□□□□□□
 Part Revision Code
- Structure 2
 □□□□□□-□□□□□□-□□
 Color Code for Painted Part
- Standard Hardware Number
 (for bolts, nuts, washer, or the like)
 □□□□□□□□
 Size Code
 Material and Surface Treatment Code
 Item Code

5) Description and Additional Information

The part name, the location, the size, and the serial number as additional information, etc. are described here. Use them to find out and check the part required.

When a part number is changed without change of the product revision code and the changed parts are not interchangeable, the serial number of the product is noted as follows;

- (FA130 - 100001) : Affected units are from beginning of the product of the product code up to and including this serial number.
- (FA130 - 100002 -) : Affected units are from this serial number and above.
- (FA130 - 100002 - FA130 - 110001) : Affected units are in this serial number range.

6) Quantity

The figure shows quantity of the part required at the indicated position on the illustration and for the specified product revision code.

The asterisk (*) on this column means the part can be used as the substitute on the product and is supplied until the stock is exhausted.

Note:Some small parts will be supplied by units.

Example: If six (6) bolts are ordered and the minimum quantity per unit is five (5), two (2), units of the bolt will be delivered.

7) Product Revision Code

This Code indicates an important change which affects the service parts interchangeability.

3. ABBREVIATIONS

#.....Number	FR.....Front	RH.....Right Hand
&.....And	G.....Gram	RPM.....Revolutions Per Minute
(+).....Plus	HEX.....Hexagonal	RR.....Rear
(-).....Minus	ID=.....Inside Diameter	STD.....Standard
2ND.....Second	IN.....Inch	T.....Teeth
3RD.....Third	L=.....Length	T=.....Thickness
4TH.....Fourth	LH.....Left Hand	U/S.....Under Size
A.....Ampere	LWR.....Lower	UPP.....Upper
AR.....As Required	MM.....Millimeter	V.....Volt
ASSY.....Assembly	O/S.....Over Size	W.....Watt
CNT.....Center	OD=.....Outside Diameter	
COMP.....Complete	REF.....Reference	

This catalog covers:

FJ100D- □ S52

GRID NO.

B-01

This grid covers:

PICTORIAL INDEX

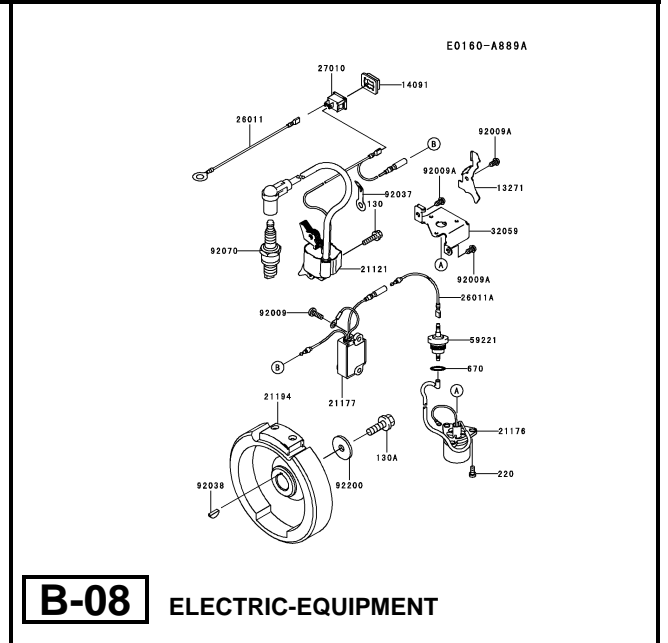
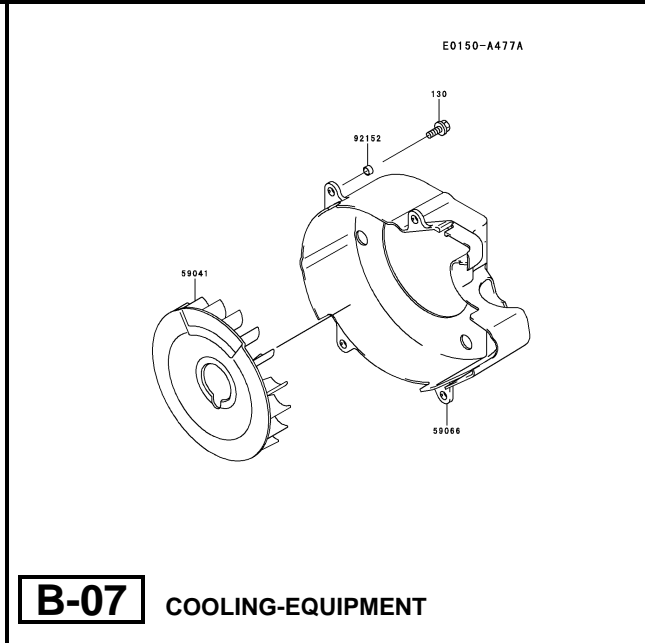
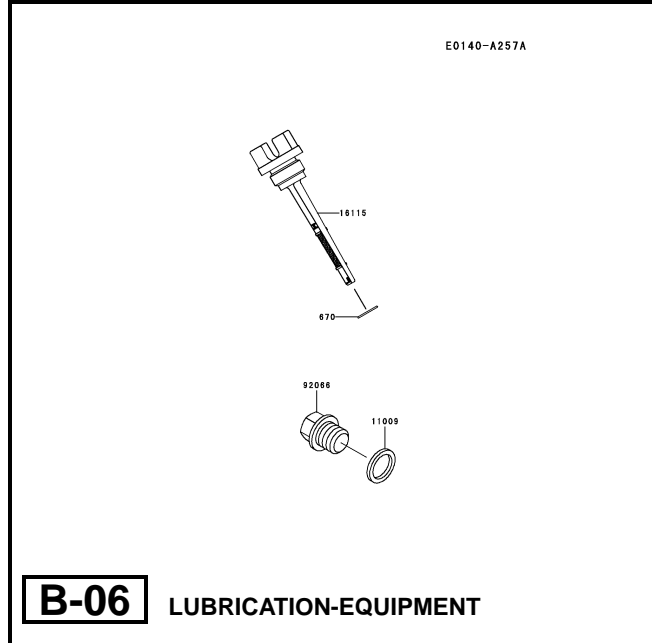
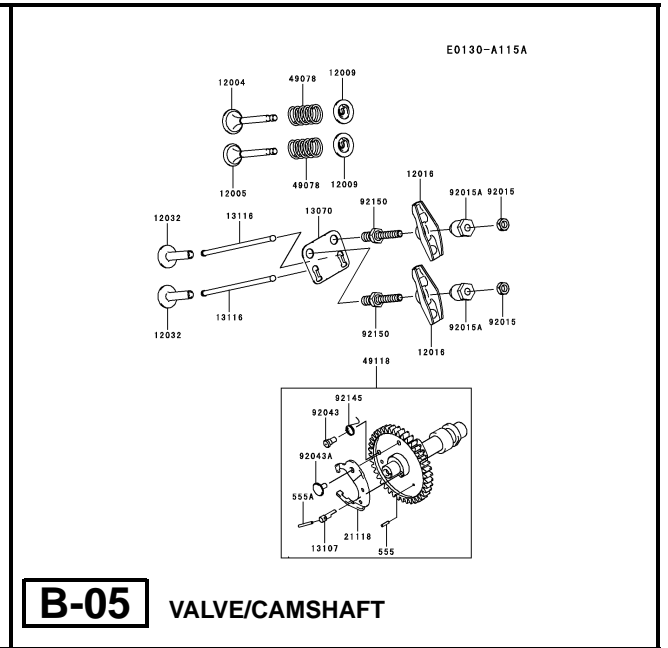
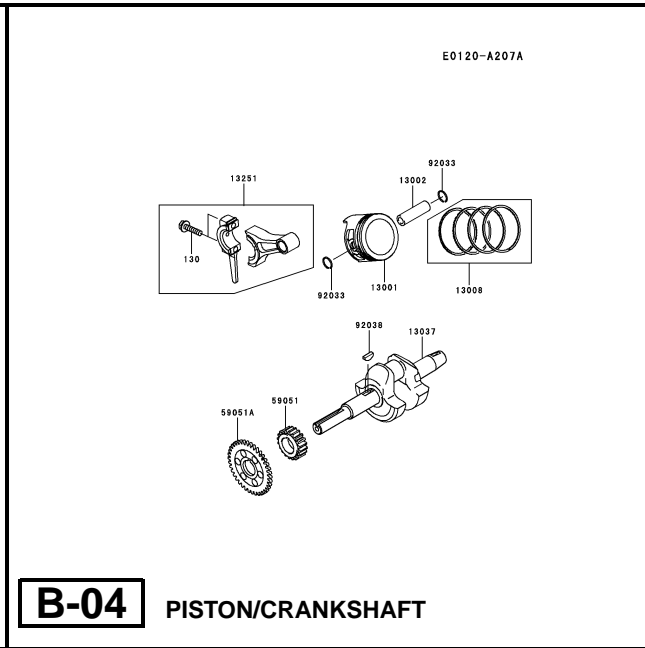
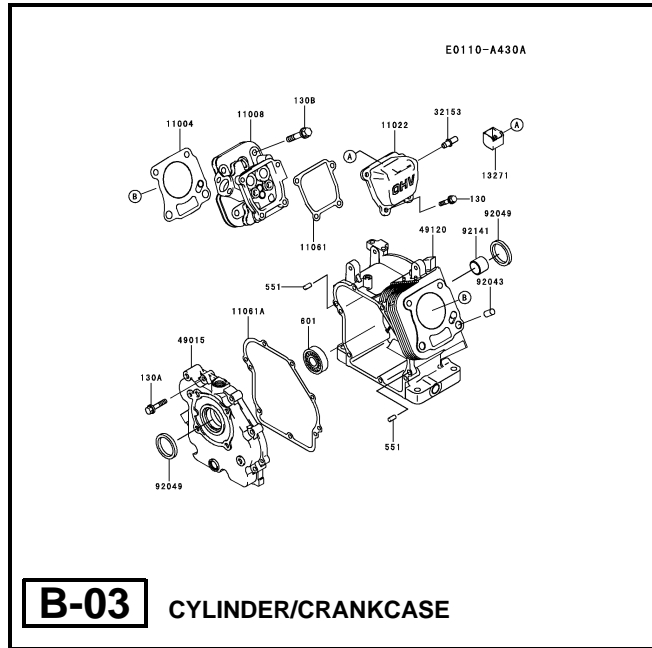

This catalog covers:

FJ100D- □ S52

GRID NO.

B-02

This grid covers:

PICTORIAL INDEX

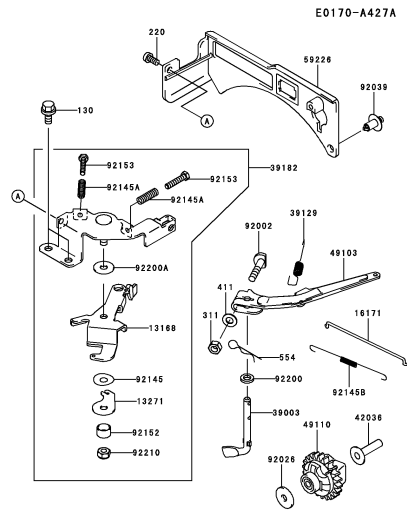

B-09

CONTROL-EQUIPMENT

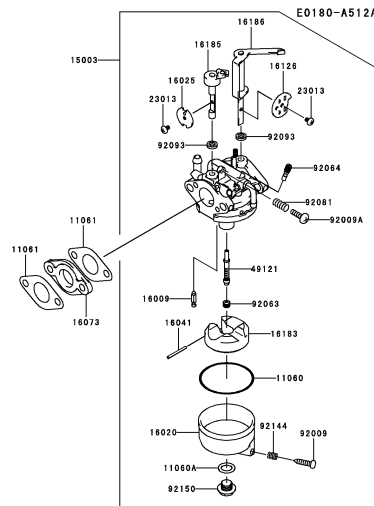

B-10

CARBURETOR

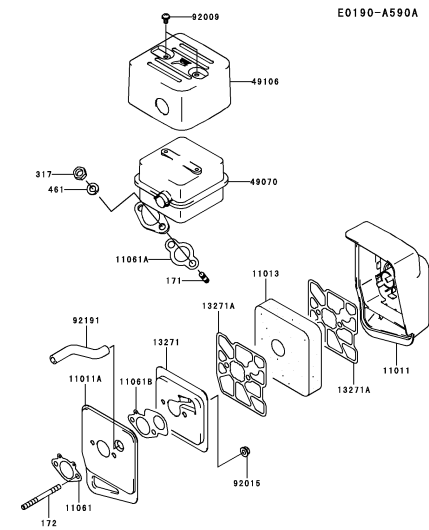

B-11

AIR-FILTER/MUFFLER

This catalog covers:

FJ100D- □ S52

GRID NO.

C-01

This grid covers:

PICTORIAL INDEX

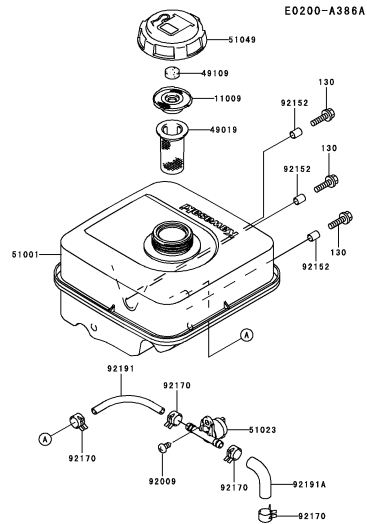

C-03

FUEL-TANK/FUEL-VALVE

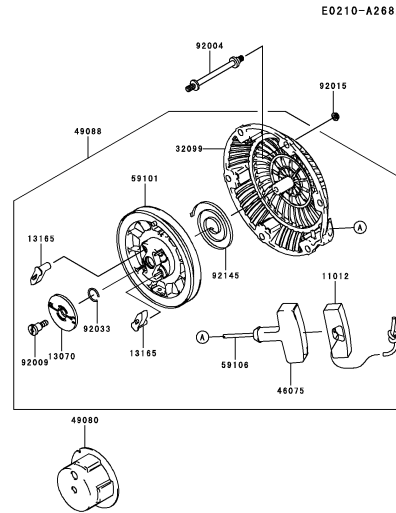

C-04

STARTER

This catalog covers:

FJ100D- □ S52

GRID NO.

D-01

This grid covers:

PICTORIAL INDEX

F0290-B061A

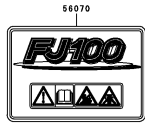

D-03 LABEL

F0300-A018A

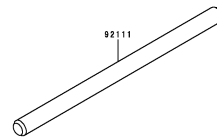
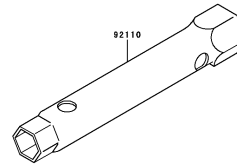

D-04 TOOL

This catalog covers:

FJ100D- □ S52

GRID NO.

B-03

This grid covers:

CYLINDER/CRANKCASE

E0110-A430A

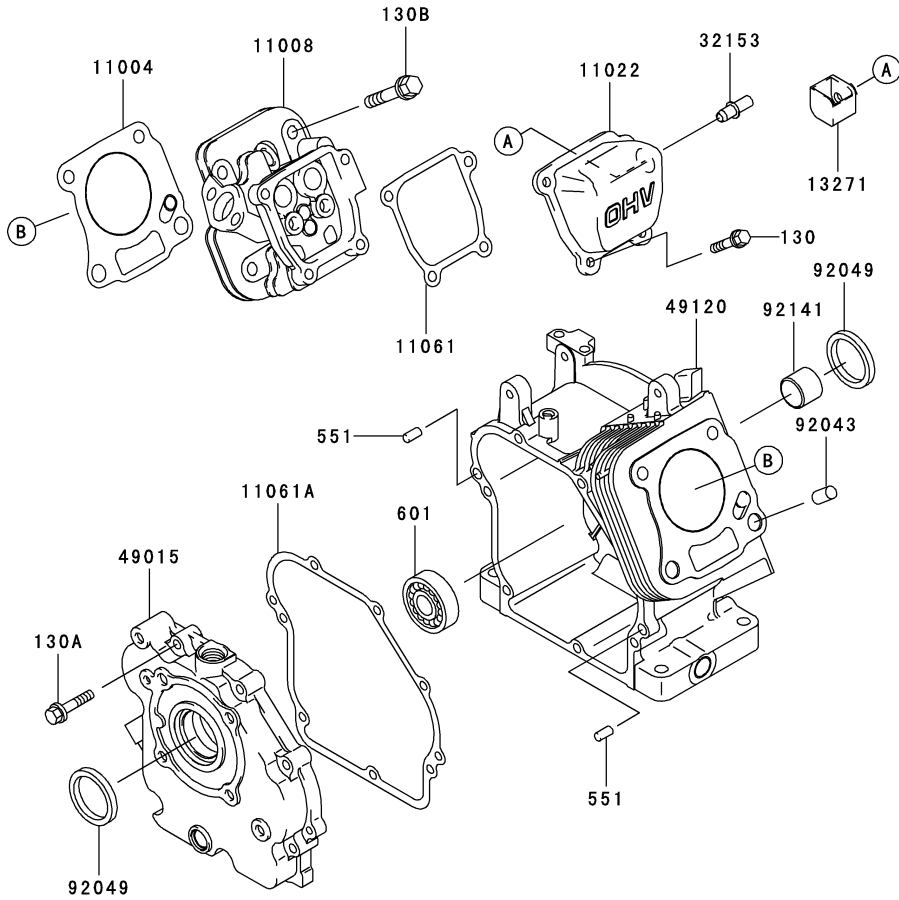

Ref. No.	Part No.	Description	Quantity
11004	11004-2143	GASKET-HEAD	1
11008	11008-2156	HEAD-COMP-CYLINDER	1
11022	11022-2075	CASE-ROCKER	1
11061	11061-2100	GASKET,CASE-ROCKER	1
11061A	11061-2104	GASKET,COVER-CRANKCA	1
13271	13271-2202	PLATE,BREATHER	1
32153	32153-2093	PIPE	1
49015	49015-6262	COVER-CRANKCASE	1
49120	49120-6139	CRANKCASE-COMP	1
92043	92043-1037	PIN	2
92049	92049-2001	SEAL-OIL	2
92141	92141-2120	BEARING-PLANE	1
130	130B0612	BOLT-FLANGED	4
130A	130G0630	BOLT-FLANGED	7
130B	130T0840	BOLT-FLANGED	4
551	551A0612	PIN-DOWEL	2
601	601A6004	BEARING-BALL	1

This catalog covers:

FJ100D- □ S52

GRID NO.

B-04

This grid covers:

PISTON/CRANKSHAFT

E0120-A207A

Ref. No.	Part No.	Description	Quantity
13001	13001-2155	PISTON-ENGINE	1
13002	13002-2083	PIN-PISTON	1
13008	13008-2061	RING-SET-PISTON	1
13037	13037-2569	CRANKSHAFT	1
13251	13251-2068	ROD-ASSY-CONNECTING	1
59051	59051-2367	GEAR-SPUR,CRANK	1
59051A	59051-2368	GEAR-SPUR,GOVERNOR	1
92033	92033-2051	RING-SNAP	2
92038	92038-003	KEY	1
130	130G0625	BOLT-FLANGED	2

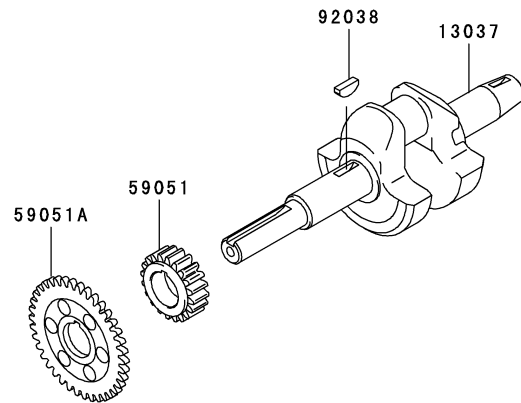
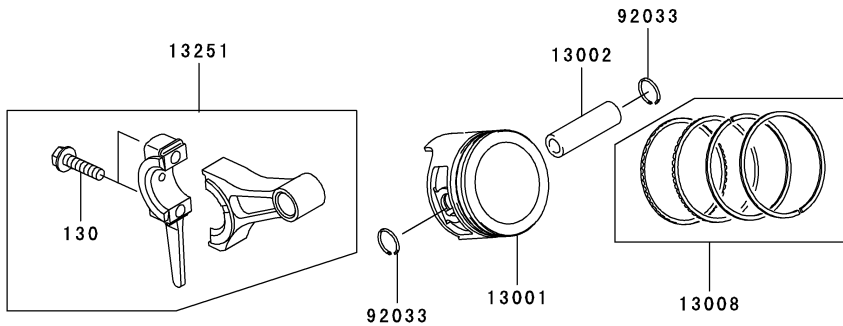

This catalog covers:

FJ100D- □ S52

GRID NO.

B-05

This grid covers:

VALVE/CAMSHAFT

E0130-A115A

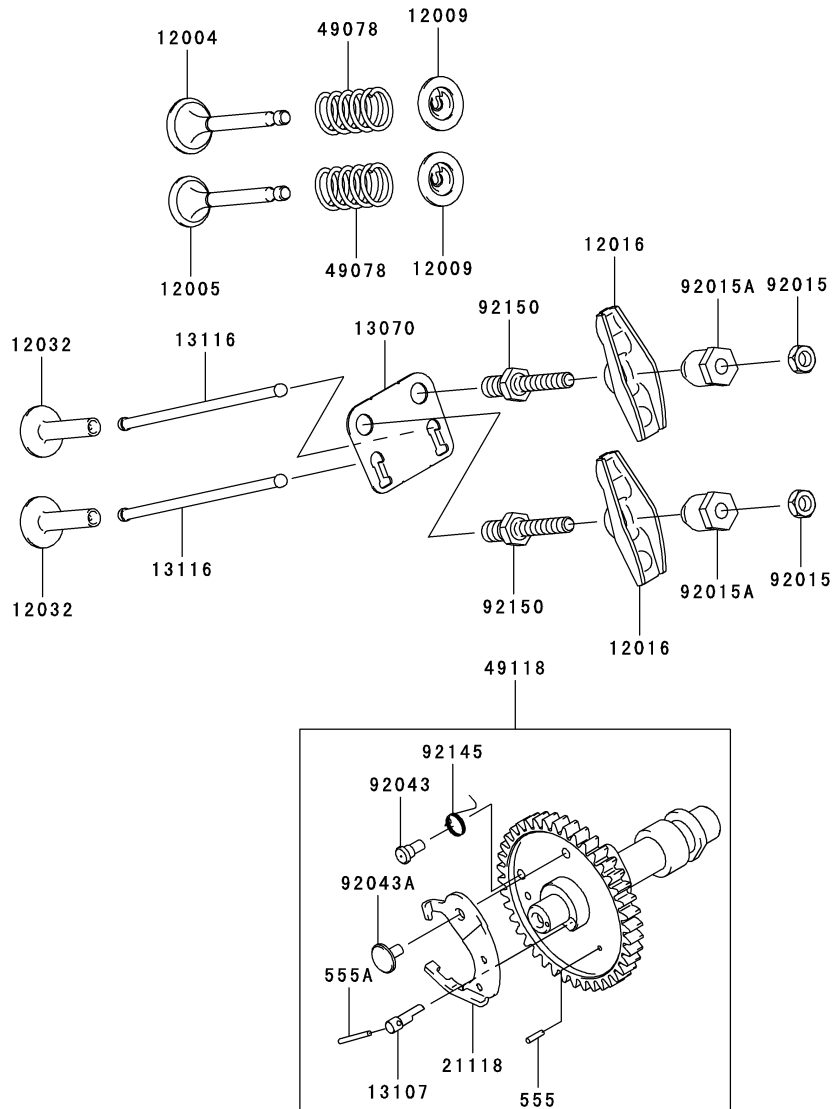

Ref. No.	Part No.	Description	Quantity
12004	12004-2114	VALVE-INTAKE	1
12005	12005-2102	VALVE-EXHAUST	1
12009	12009-2062	RETAINER-VALVE SPRING	2
12016	12016-2059	ARM-ROCKER	2
12032	12032-2065	TAPPET	2
13070	13070-2111	GUIDE, ROD-PUSH	1
13107	13107-2294	SHAFT	1
13116	13116-2075	ROD-PUSH	2
21118	21118-2094	DECOMPRESSOR	1
49078	49078-2085	SPRING-ENGINE VALVE	2
49118	49118-2147	CAMSHAFT-COMP	1
92015	92015-2240	NUT	2
92015A	92015-2253	NUT	2
92043	92043-2240	PIN, SPRING	1
92043A	92043-2242	PIN, DECOMPRESSOR	1
92145	92145-2107	SPRING	1
92150	92150-2198	BOLT	2
555	555A0208	PIN-SPRING	2
555A	555A0220	PIN-SPRING	1

This catalog covers:

FJ100D- □ S52

GRID NO.

B-06

This grid covers:

LUBRICATION-EQUIPMENT

E0140-A257A

Ref. No.	Part No.	Description	Quantity
11009	11009-2175	GASKET,14.2X19X2	1
16115	16115-2128	CAP-OIL FILLER	1
92066	92066-2203	PLUG,DRAIN	1
670	670B2015	RING-O	1

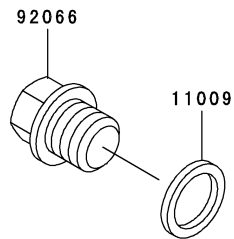
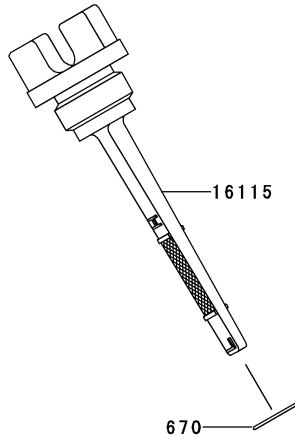

This catalog covers:

FJ100D- □ S52

GRID NO.

B-07

This grid covers:

COOLING-EQUIPMENT

E0150-A477A

Ref. No.	Part No.	Description	Quantity
59041	59041-2095	FAN	1
59066	59066-2764	HOUSING-FAN	1
92152	92152-2082	COLLAR	4
130	130G0614	BOLT-FLANGED	4

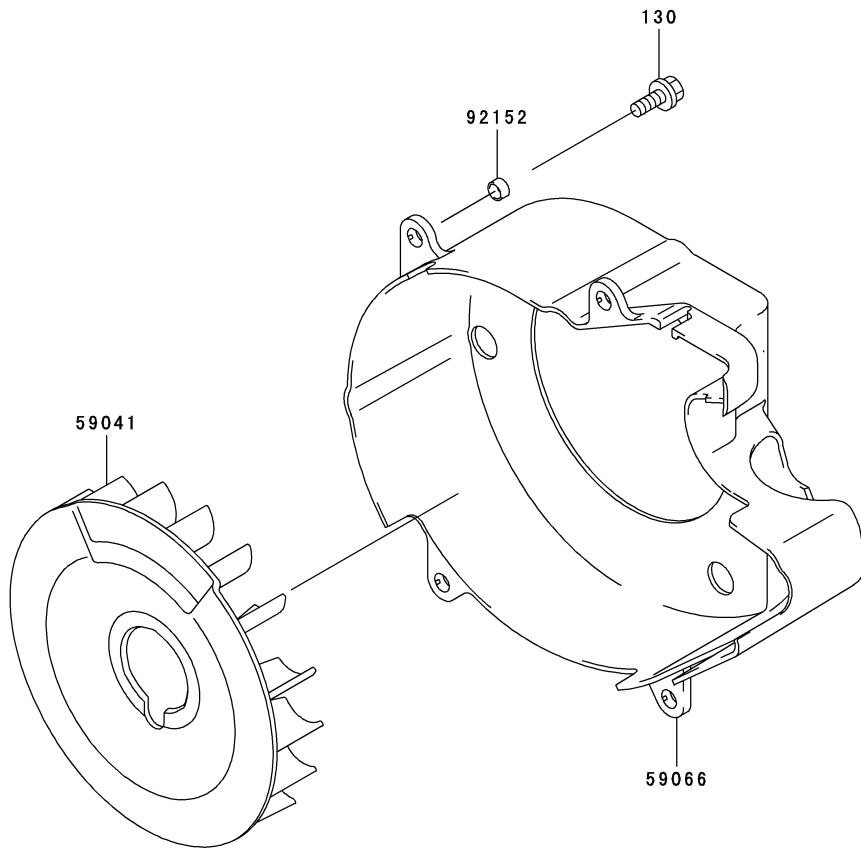

This catalog covers:

FJ100D- □ S52

GRID NO.

B-08

This grid covers:

ELECTRIC-EQUIPMENT

E0160-A889A

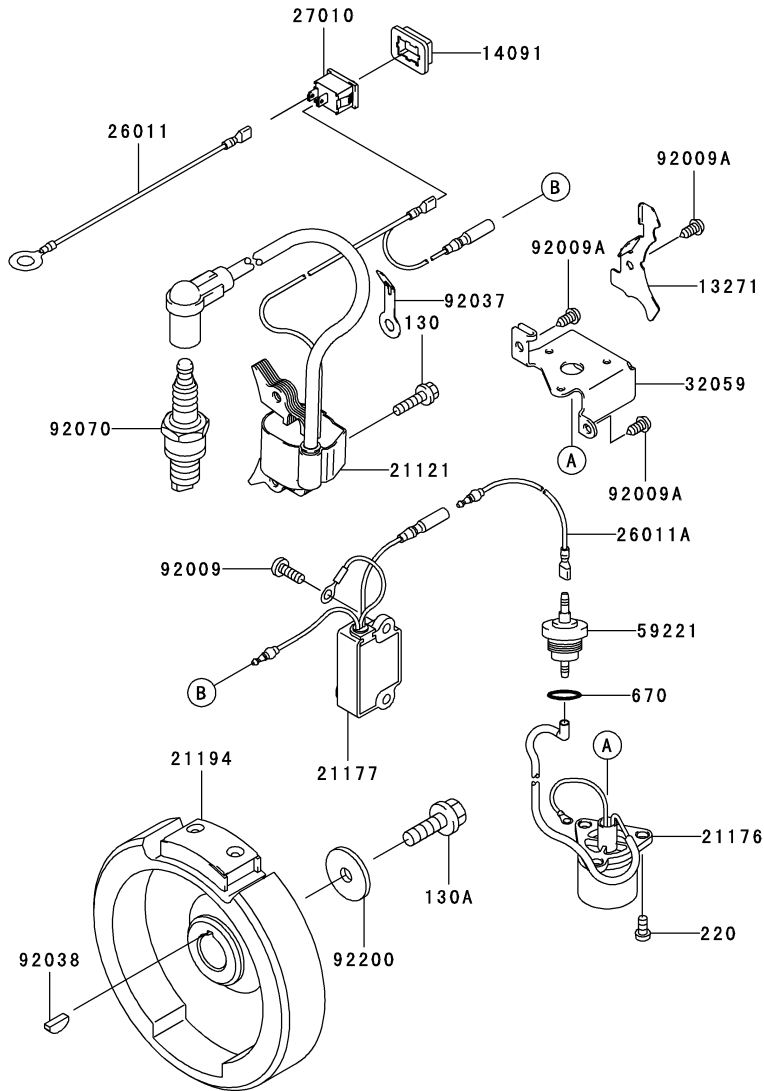

Ref. No.	Part No.	Description	Quantity
		A	
13271	13271-2225	PLATE	1
14091	14091-2096	COVER	1
21121	21121-2096	COIL-IGNITION	1
21176	21176-2107	SENSOR	1
21177	21177-2064	CONTROLLER	1
21194	21194-2346	FLYWHEEL-COMP	1
26011	26011-2371	WIRE-LEAD,SWITCH	1
26011A	26011-2377	WIRE-LEAD,L=120	1
27010	27010-2231	SWITCH,IGNITION	1
32059	32059-2102	BRACKET-SWITCH	1
59221	59221-2123	CONNECTOR-CORD	1
92009	92009-2102	SCREW	2
92009A	92009-2308	SCREW	3
92037	92037-2165	CLAMP	1
92038	92038-003	KEY	1
92070	92070-2117	PLUG-SPARK,BR6HS(NGK),SOLID	1
92200	92200-2142	WASHER	1
130	130B0520	BOLT-FLANGED	2
130A	130T0825	BOLT-FLANGED	1
220	220B0408	SCREW-PAN-CROS	3
670	670B2015	RING-O	1

This catalog covers:

FJ100D- □ S52

GRID NO.

B-09

This grid covers:

CONTROL-EQUIPMENT

E0170-A427A

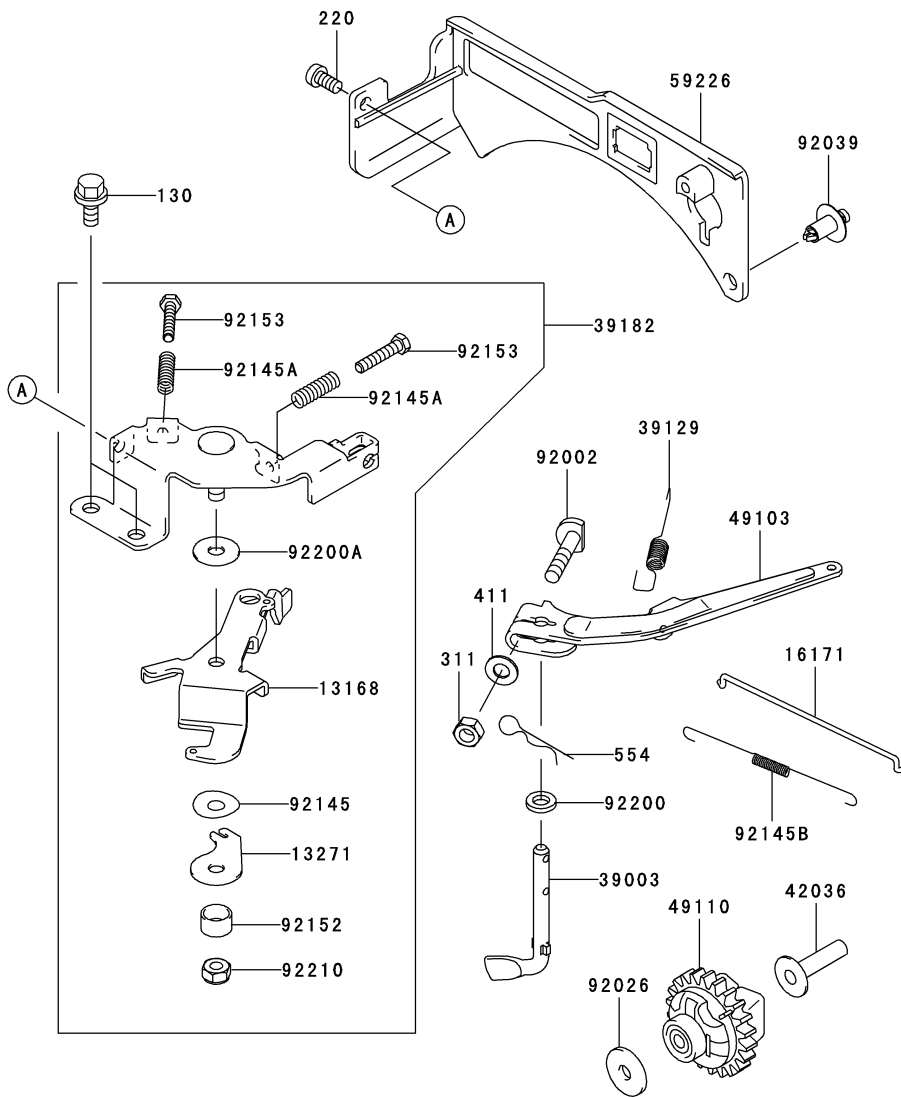

Ref. No.	Part No.	Description	Quantity
13168	13168-2481	LEVER	1
13271	13271-2205	PLATE	1
16171	16171-2095	LINK	1
39003	39003-2073	ARM-PIVOT	1
39129	39129-2104	SPRING-GOVERNOR	1
39182	39182-2179	PANEL-ASSY-CONTROL	1
42036	42036-2060	SLEEVE	1
49103	49103-2157	ARM-GOVERNOR	1
49110	49110-2086	GOVERNOR-ASSY	1
59226	59226-2331	PANEL-CONTROL	1
92002	92002-2269	BOLT	1
92026	92200-2036	SPACER	1
92039	92039-2076	RIVET	1
92145	92145-2108	SPRING	1
92145A	92145-2109	SPRING	2
92145B	92145-2111	SPRING	1
92152	92152-2081	COLLAR	1
92153	92153-2067	BOLT,4X22	2
92200	92200-2029	WASHER,6.5X11.5X2.0	1
92200A	92200-2141	WASHER,6.3X18X1	1
92210	92210-2095	NUT,LOCK,6MM	1
130	130B0612	BOLT-FLANGED	2
220	220B0510	SCREW-PAN-CROS	1
311	311B0600	NUT-HEX	1
411	411B0600	WASHER-PLAIN	1
554	554A0600	PIN-SNAP	1

This catalog covers:

FJ100D- □ S52

GRID NO.

B-10

This grid covers:

CARBURETOR

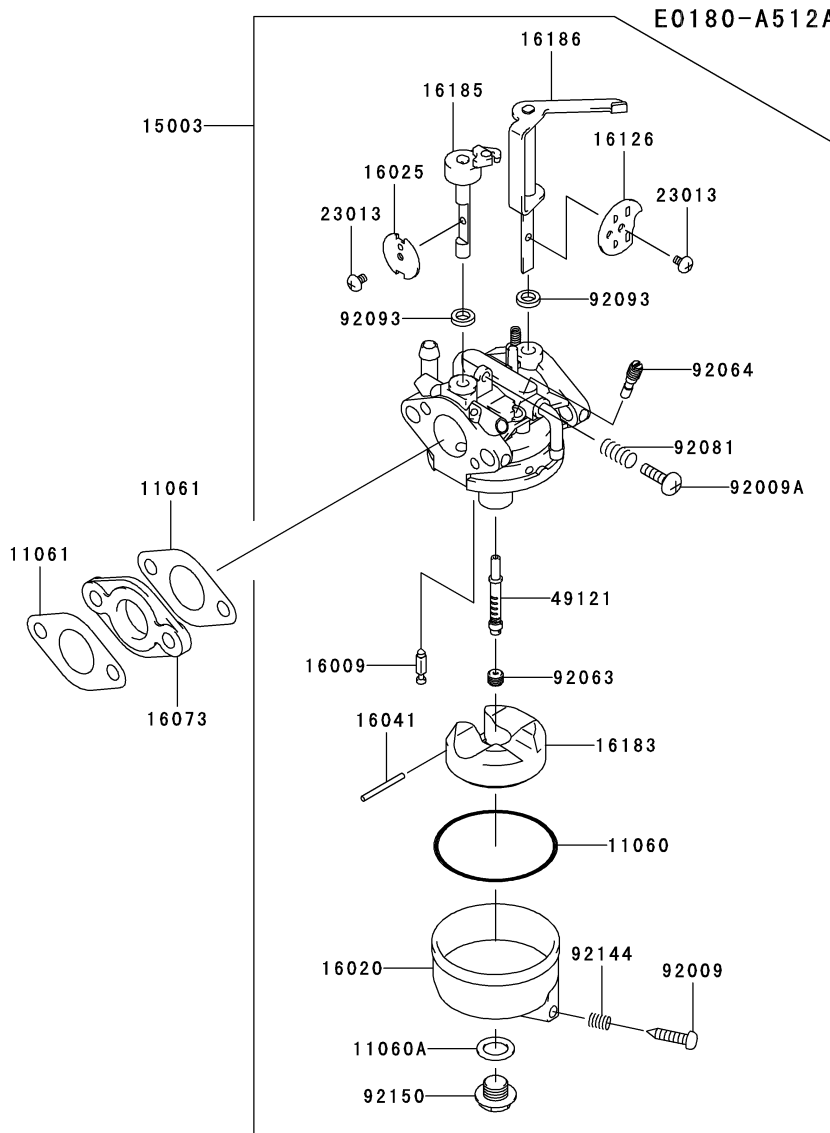

Ref. No.	Part No.	Description	Quantity
11060	11060-2190	GASKET	1
11060A	11060-2191	GASKET	1
11061	11061-2103	GASKET	2
15003	15003-2823	CARBURETOR-ASSY	1
16009	16009-2136	NEEDLE-JET	1
16020	16020-2129	CHAMBER-FLOAT	1
16025	16025-2166	VALVE-THROTTLE	1
16041	16041-2224	SHAFT-CARBURETOR, FLOAT	1
16073	16073-2212	INSULATOR, INSULATOR	1
16126	16126-2236	VALVE	1
16183	16183-2002	FLOAT-ASSY	1
16185	16185-2044	VALVE-ASSY-THROTTLE	1
16186	16186-2039	VALVE-ASSY-CHOKE	1
23013	23013-2058	SCREW-ASSY	2
49121	49121-2241	NOZZLE-MAIN	1
92009	92009-2348	SCREW	1
92009A	92009-2349	SCREW	1
92063	92063-2429	JET-MAIN, #58	1
92064	92064-2136	JET-PILOT, #36	1
92081	92081-2234	SPRING	1
92093	92093-2100	SEAL	2
92144	92144-2333	SPRING	1
92150	92150-2263	BOLT	1

This catalog covers:

FJ100D- □ S52

GRID NO.

B-11

This grid covers:

AIR-FILTER/MUFFLER

E0190-A590A

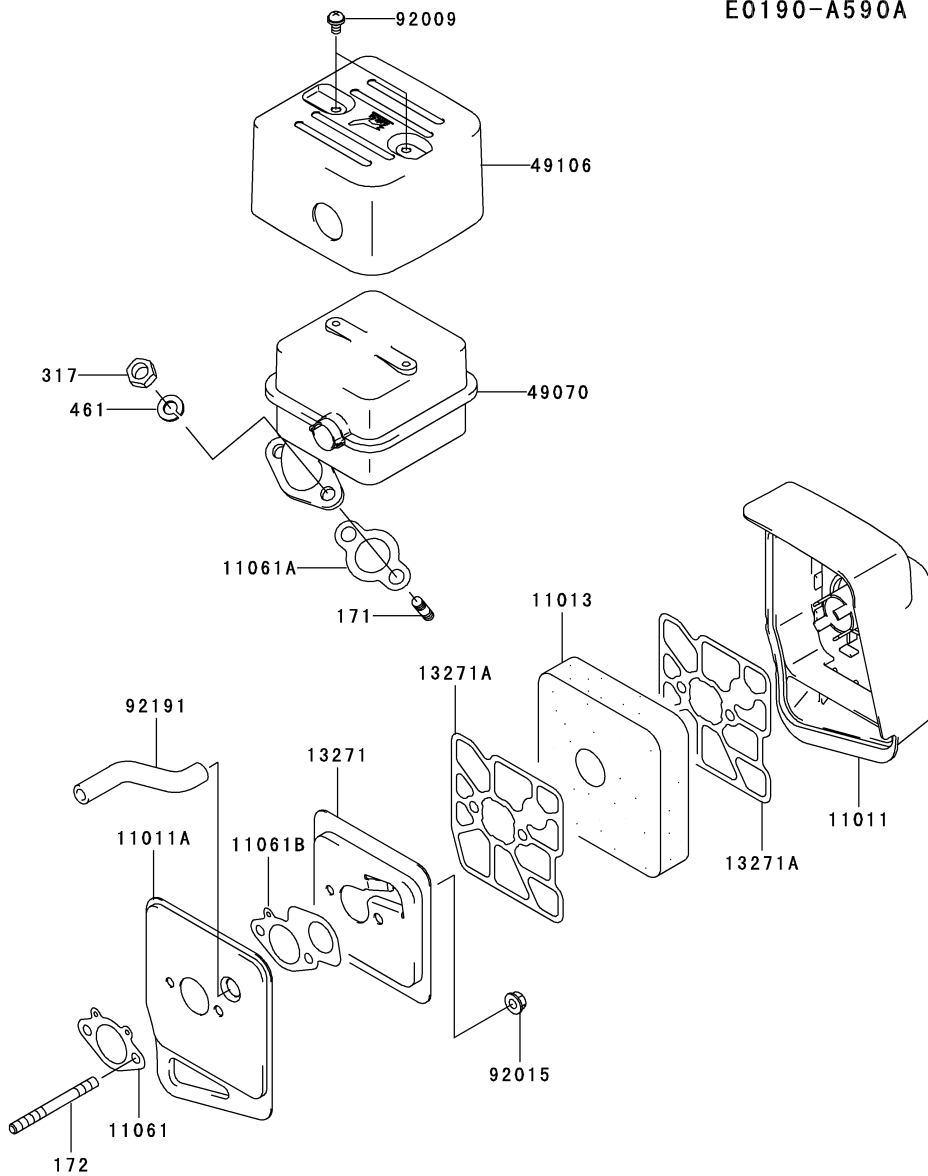

Ref. No.	Part No.	Description	Quantity
11011	11011-2329	CASE-AIR FILTER,UPP	1
11011A	11011-2336	CASE-AIR FILTER,LOW	1
11013	11013-2198	ELEMENT-AIR FILTER	1
11061	11061-2101	GASKET,CARB	1
11061A	11061-2102	GASKET,MUFFLER	1
11061B	11061-2111	GASKET	1
13271	13271-2203	PLATE	1
13271A	13271-2204	PLATE,ELEMENT	2
49070	49070-2746	MUFFLER-COMP	1
49106	49106-2655	COVER-MUFFLER	1
92009	92009-2322	SCREW	2
92015	92015-1193	NUT	2
92191	92191-2156	TUBE,7X12X105	1
171	171G0816	BOLT-STUD	2
172	172G0670	BOLT-STUD	2
317	317R0800	NUT-HEX-SMALL	2
461	461F0800	WASHER-SPRING	2

This catalog covers:

FJ100D- □ S52

GRID NO.

C-03

This grid covers:

FUEL-TANK/FUEL-VALVE

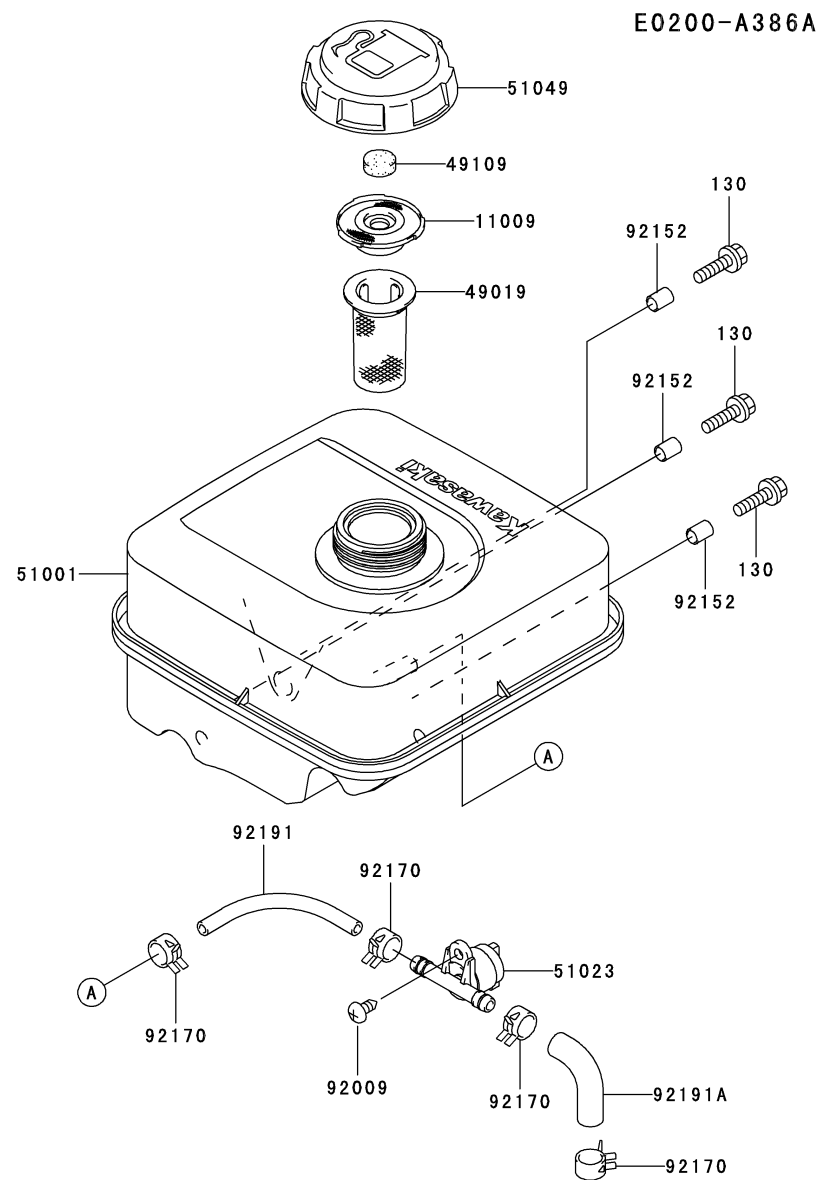

E0200-A386A

Ref. No.	Part No.	Description	Quantity
11009	11009-2831	GASKET,BREATHER	1
49019	49019-2060	FILTER-FUEL	1
49109	49109-2054	ELEMENT-BREATHER,TANK	1
51001	51001-2318	TANK-COMP-FUEL	1
51023	51023-2169	TAP-ASSY	1
51049	51049-2100	CAP-TANK	1
92009	92009-2308	SCREW	1
92152	92152-2080	COLLAR	3
92170	92170-2043	CLAMP	4
92191	92191-2157	TUBE,7X12X95	1
92191A	92191-2158	TUBE	1
130	130G0620	BOLT-FLANGED	3

This catalog covers:

FJ100D- □ S52

GRID NO.

C-04

This grid covers:

STARTER

E0210-A268A

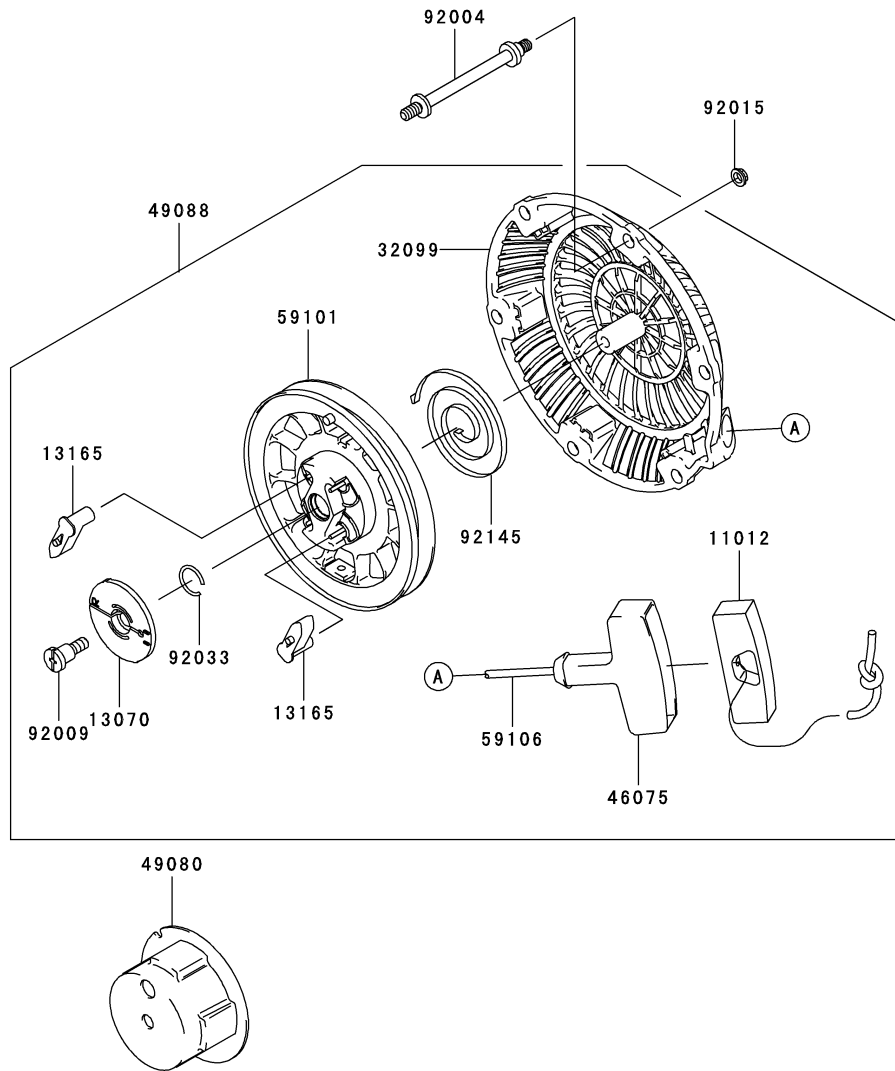

Ref. No.	Part No.	Description	Quantity
11012	11012-2255	CAP,GRIP	1
13070	13070-2112	GUIDE	1
13165	13165-2099	PAWL,RECOIL STARTER	2
32099	32099-2382	CASE,RECOIL STARTER	1
46075	46075-2091	GRIP,RECOIL STARTER	1
49080	49080-2186	PULLEY-STARTING	1
49088	49088-2514	STARTER-RECOIL	1
59101	59101-2113	REEL,RECOIL STARTER	1
59106	59106-2162	ROPE,4X1450	1
92004	92004-2156	STUD	3
92009	92009-2347	SCREW	1
92015	92015-1193	NUT	3
92033	92033-2160	RING-SNAP	1
92145	92145-2121	SPRING	1

This catalog covers:

FJ100D- □ S52

GRID NO.

D-03

This grid covers:

LABEL

F0290-B061A

Ref. No.	Part No.	Description	Quantity
56030	56030-2386	LABEL,CHOKE	1
56030A	56030-2600	LABEL	1
56070	56070-2071	LABEL-WARNING	1
56080	56080-2077	LABEL-BRAND	1

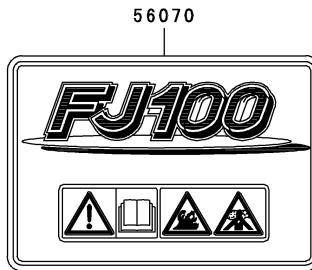
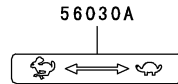
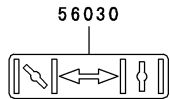

This catalog covers:

FJ100D- □ S52

GRID NO.

D-04

This grid covers:

TOOL

F0300-A018A

Ref. No.	Part No.	Description	Quantity
92110	92110-2098	TOOL-WRENCH,14X21	1
92111	92111-2053	TOOL-BAR	1

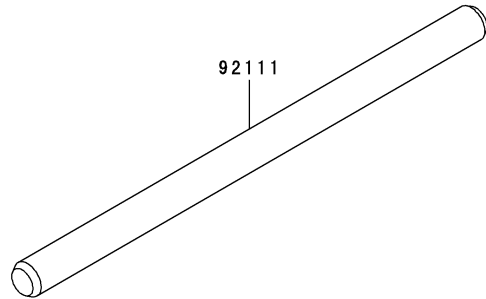
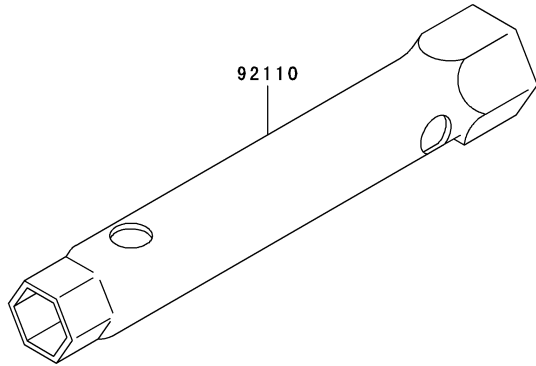

This catalog covers:

FJ100D- □ S52

GRID NO.

H-09

This grid covers:

PART NAME INDEX

AIR-FILTER/MUFFLER.....	B-11
CARBURETOR.....	B-10
CONTROL-EQUIPMENT.....	B-09
COOLING-EQUIPMENT.....	B-07
CYLINDER/CRANKCASE.....	B-03
ELECTRIC-EQUIPMENT.....	B-08
FUEL-TANK/FUEL-VALVE.....	C-03
LABEL.....	D-03
LUBRICATION-EQUIPMENT.....	B-06
PISTON/CRANKSHAFT.....	B-04
STARTER.....	C-04
TOOL.....	D-04
VALVE/CAMSHAFT.....	B-05

This catalog covers:

FJ100D- □ S52

GRID NO.

H-10

This grid covers:

NUMERICAL PARTS INDEX

Part No.	Grid No.	Part No.	Grid No.	Part No.	Grid No.	Part No.	Grid No.	Part No.	Grid No.
11004-2143.....	B-03	171G0816.....	B-11	92002-2269.....	B-09				
11008-2156.....	B-03	172G0670.....	B-11	92004-2156.....	C-04				
11009-2175.....	B-06	21118-2094.....	B-05	92009-2102.....	B-08				
11009-2831.....	C-03	21121-2096.....	B-08	92009-2308.....	B-08				
11011-2329.....	B-11	21176-2107.....	B-08	92009-2308.....	C-03				
11011-2336.....	B-11	21177-2064.....	B-08	92009-2322.....	B-11				
11012-2255.....	C-04	21194-2346.....	B-08	92009-2347.....	C-04				
11013-2198.....	B-11	220B0408.....	B-08	92009-2348.....	B-10				
11022-2075.....	B-03	220B0510.....	B-09	92009-2349.....	B-10				
11060-2190.....	B-10	23013-2058.....	B-10	92015-1193.....	B-11				
11060-2191.....	B-10	26011-2371.....	B-08	92015-1193.....	C-04				
11061-2100.....	B-03	26011-2377.....	B-08	92015-2240.....	B-05				
11061-2101.....	B-11	27010-2231.....	B-08	92015-2253.....	B-05				
11061-2102.....	B-11	311B0600.....	B-09	92033-2051.....	B-04				
11061-2103.....	B-10	317R0800.....	B-11	92033-2160.....	C-04				
11061-2104.....	B-03	32059-2102.....	B-08	92037-2165.....	B-08				
11061-2111.....	B-11	32099-2382.....	C-04	92038-003.....	B-04				
12004-2114.....	B-05	32153-2093.....	B-03	92038-003.....	B-08				
12005-2102.....	B-05	39003-2073.....	B-09	92039-2076.....	B-09				
12009-2062.....	B-05	39129-2104.....	B-09	92043-1037.....	B-03				
12016-2059.....	B-05	39182-2179.....	B-09	92043-2240.....	B-05				
12032-2065.....	B-05	411B0600.....	B-09	92043-2242.....	B-05				
13001-2155.....	B-04	42036-2060.....	B-09	92049-2001.....	B-03				
13002-2083.....	B-04	46075-2091.....	C-04	92063-2429.....	B-10				
13008-2061.....	B-04	461F0800.....	B-11	92064-2136.....	B-10				
13037-2569.....	B-04	49015-6262.....	B-03	92066-2203.....	B-06				
13070-2111.....	B-05	49019-2060.....	C-03	92070-2117.....	B-08				
13070-2112.....	C-04	49070-2746.....	B-11	92081-2234.....	B-10				
130B0520.....	B-08	49078-2085.....	B-05	92093-2100.....	B-10				
130B0612.....	B-03	49080-2186.....	C-04	92110-2098.....	D-04				
130B0612.....	B-09	49088-2514.....	C-04	92111-2053.....	D-04				
130G0614.....	B-07	49103-2157.....	B-09	92141-2120.....	B-03				
130G0620.....	C-03	49106-2655.....	B-11	92144-2333.....	B-10				
130G0625.....	B-04	49109-2054.....	C-03	92145-2107.....	B-05				
130G0630.....	B-03	49110-2086.....	B-09	92145-2108.....	B-09				
130T0825.....	B-08	49118-2147.....	B-05	92145-2109.....	B-09				
130T0840.....	B-03	49120-6139.....	B-03	92145-2111.....	B-09				
13107-2294.....	B-05	49121-2241.....	B-10	92145-2121.....	C-04				
13116-2075.....	B-05	51001-2318.....	C-03	92150-2198.....	B-05				
13165-2099.....	C-04	51023-2169.....	C-03	92150-2263.....	B-10				
13168-2481.....	B-09	51049-2100.....	C-03	92152-2080.....	C-03				
13251-2068.....	B-04	551A0612.....	B-03	92152-2081.....	B-09				
13271-2202.....	B-03	554A0600.....	B-09	92152-2082.....	B-07				
13271-2203.....	B-11	555A0208.....	B-05	92153-2067.....	B-09				
13271-2204.....	B-11	555A0220.....	B-05	92170-2043.....	C-03				
13271-2205.....	B-09	56030-2386.....	D-03	92191-2156.....	B-11				
13271-2225.....	B-08	56030-2600.....	D-03	92191-2157.....	C-03				
14091-2096.....	B-08	56070-2071.....	D-03	92191-2158.....	C-03				
15003-2823.....	B-10	56080-2077.....	D-03	92200-2029.....	B-09				
16009-2136.....	B-10	59041-2095.....	B-07	92200-2036.....	B-09				
16020-2129.....	B-10	59051-2367.....	B-04	92200-2141.....	B-09				
16025-2166.....	B-10	59051-2368.....	B-04	92200-2142.....	B-08				
16041-2224.....	B-10	59066-2764.....	B-07	92210-2095.....	B-09				
16073-2212.....	B-10	59101-2113.....	C-04						
16115-2128.....	B-06	59106-2162.....	C-04						
16126-2236.....	B-10	59221-2123.....	B-08						
16171-2095.....	B-09	59226-2331.....	B-09						
16183-2002.....	B-10	601A6004.....	B-03						
16185-2044.....	B-10	670B2015.....	B-06						
16186-2039.....	B-10	670B2015.....	B-08						