

LT2317 CMA

Spare parts

Ersatzteile

Pièces détachées

Reserve onderdelen

Repuestos

Reservdelar

ILLUSTRATED PARTS LIST

MODEL NO. 96051002100

CUSTOMER CATALOG NO. LT2317 CMA

PRODUCT NO. 960 51 00-21

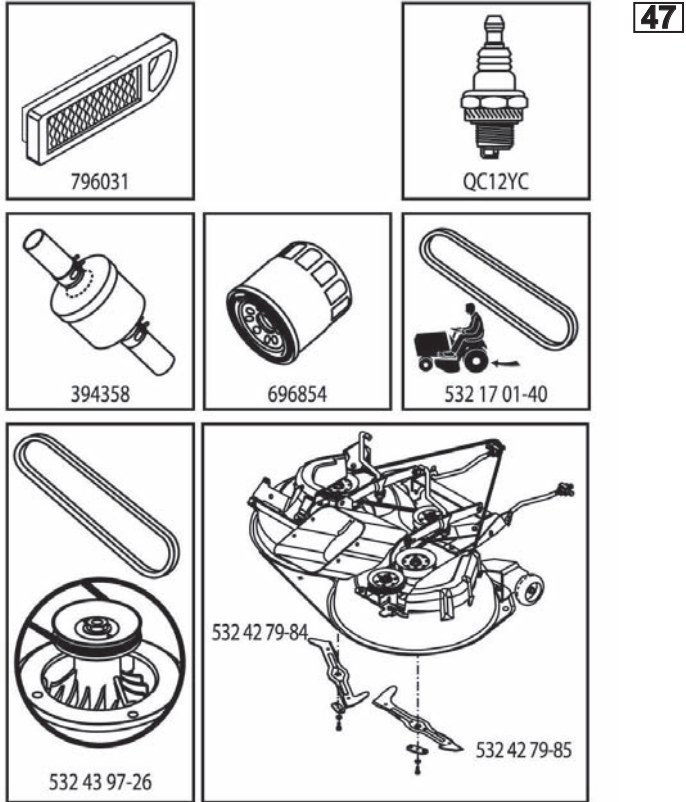

47

439833

**TRACTOR - MODEL NO. LT2317 CMA (96051002100), PROD. NO. 960 51 00-21
DECALS 27**

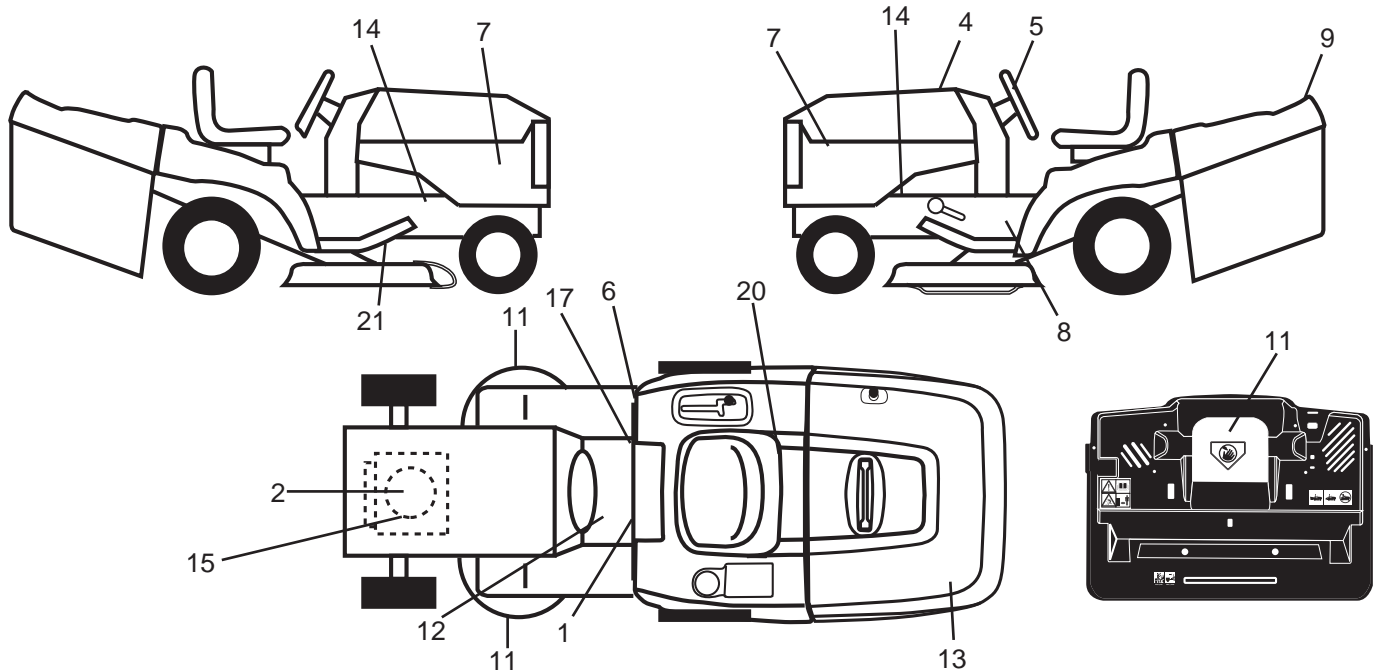

KEY NO.	PART NO.	DESCRIPTION
1	532 40 03-89	Decal Warning Sym. CE
2	532 19 68-41	Decal Warning Eng. Sym.
4	532 43 98-33	Decal Replacement
5	532 44 26-47	Decal Wheel Steering
6	532 18 04-32	Decal 100 DBA
7	532 44 10-70	Decal Side Panel
8	532 40 11-46	Decal Warning
9	532 43 74-43	Decal Fender Logo
11	532 18 21-66	Decal Mower Cut Finger Symbol
12	532 15 97-37	Decal Brake/Clutch Symbol Lt

KEY NO.	PART NO.	DESCRIPTION
13	532 43 75-46	Decal Bagger
14	532 15 97-36	Decal Chassis Hot Muffler
15	532 43 74-82	Decal Engine HP
17	532 14 08-37	Decal Saddle Brake Parking
20	532 44 09-01	Decal Bypass Fender CRD
21	532 44 11-89	Decal Hex Belt Sch 92 CRD
--	532 42 59-28	Pad Footrest RH
--	532 42 59-76	Pad Footrest LH
--	532 44 10-84	Manual Operator's (Euro)

WHEELS & TIRES

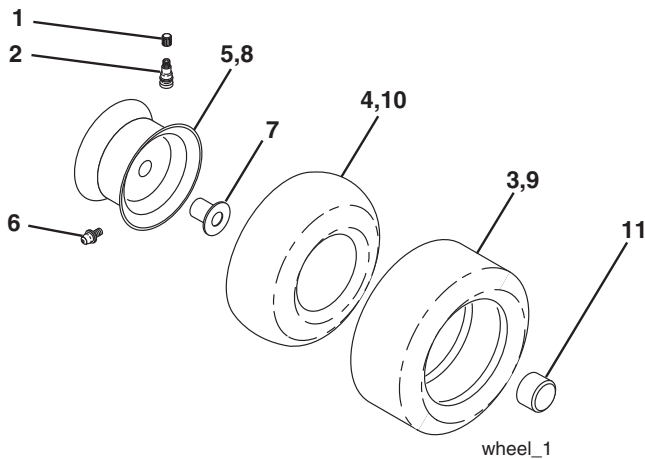

KEY NO.	PART NO.	DESCRIPTION
1	532 05 91-92	Cap Valve Tire
2	532 06 51-39	Stem Valve
3	532 10 62-22	Tire F Ts 15 x 6 0 - 6 Service
4	532 05 99-04	Tube Inner Front #35060
5	532 13 83-36	Rim Asm 6" Front Silver Service
6	532 12 49-57	Fitting Grease
7	532 12 49-59	Bearing Flange
8	532 13 83-37	Rim Asm 8" Rear Silver Service
9	532 42 05-31	Tire R Ts 20 x 10-8 Service
10	532 12 49-26	Tube Rear 9 5 x 8 Service
11	532 17 50-39	Cap Axle Blk 1 50 x 1 00
--	532 14 43-34	Sealant, Tire (10 oz. Tube)

NOTE: All component dimensions given in U.S. inches
1 inch = 25.4 mm

TRACTOR - MODEL NO. LT2317 CMA (96051002100), PROD. NO. 960 51 00-21

SCHEMATIC 38

SCH17

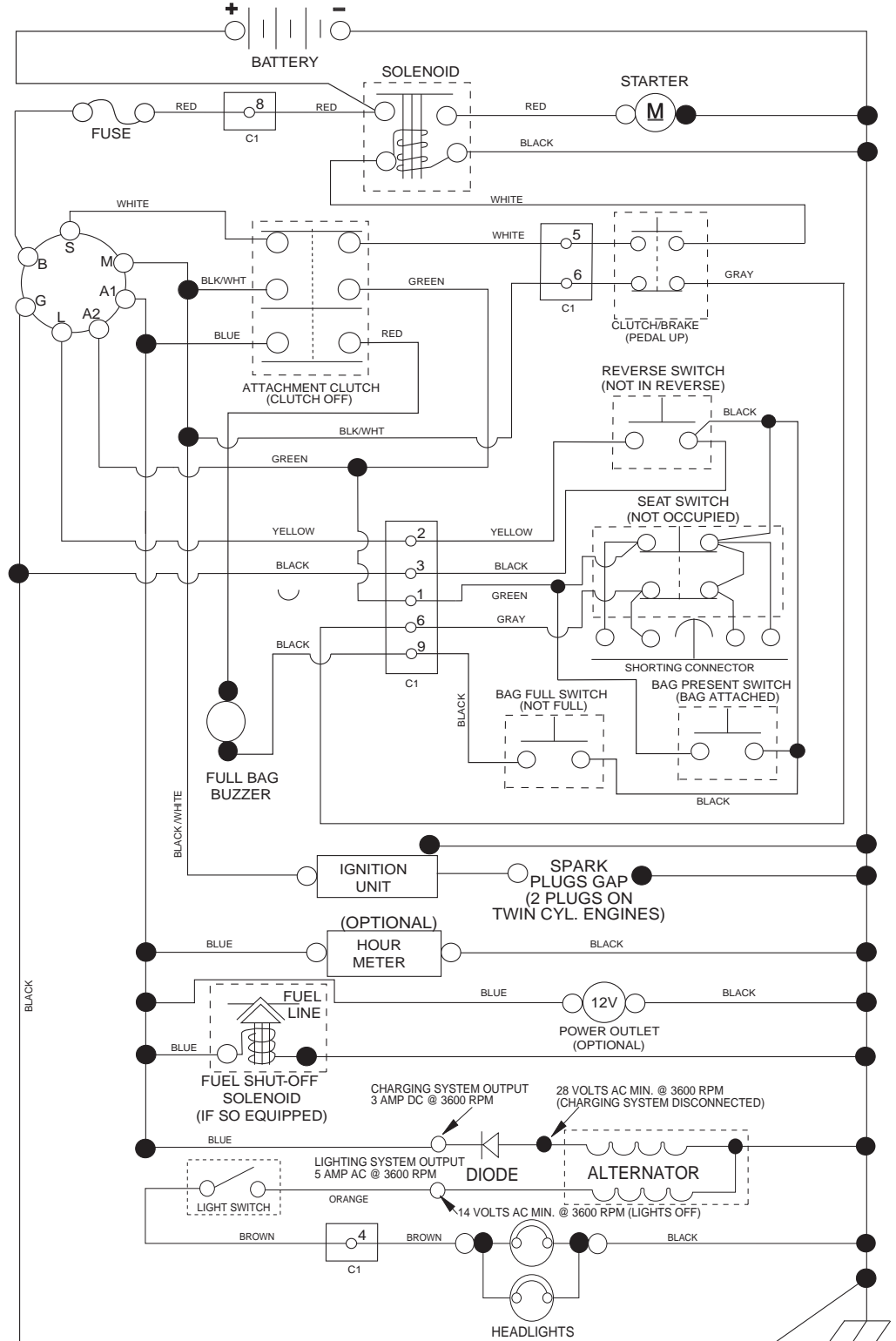

NOTE
YOUR TRACTOR IS EQUIPPED WITH A SPECIAL ALTERNATOR SYSTEM. THE LIGHTS ARE NOT CONNECTED TO THE BATTERY, BUT HAVE THEIR OWN ELECTRICAL SOURCE. BECAUSE OF THIS, THE BRIGHTNESS OF THE LIGHTS WILL CHANGE WITH ENGINE SPEED. AT IDLE THE LIGHTS WILL DIM. AS THE ENGINE SPEED IS INCREASED, THE LIGHTS WILL BECOME THEIR BRIGHTEST.

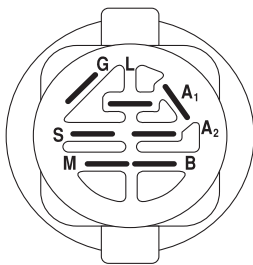

IGNITION SWITCH

POSITION	CIRCUIT	"MAKE"
OFF	M+G+A1	
RUN/OVERRIDE	B+A1	
RUN	B+A1	L+A2
START	B + S + A1	

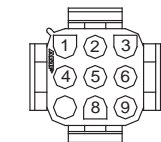

CHASSIS HARNESS CONNECTOR (C1) (MATING SIDE)

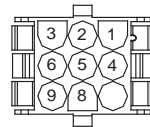

DASH HARNESS CONNECTOR (C1) (MATING SIDE)

WIRING INSULATED CLIPS
NOTE: IF WIRING INSULATED CLIPS WERE REMOVED FOR SERVICING OF UNIT, THEY SHOULD BE RE-INSTALLED TO PROPERLY SECURE YOUR WIRING.

● NON-REMOVABLE CONNECTIONS

○ REMOVABLE CONNECTIONS

**TRACTOR - MODEL NO. LT2317 CMA (96051002100), PROD. NO. 960 51 00-21
ELECTRICAL **32****

TC03S

With Service Minder Option

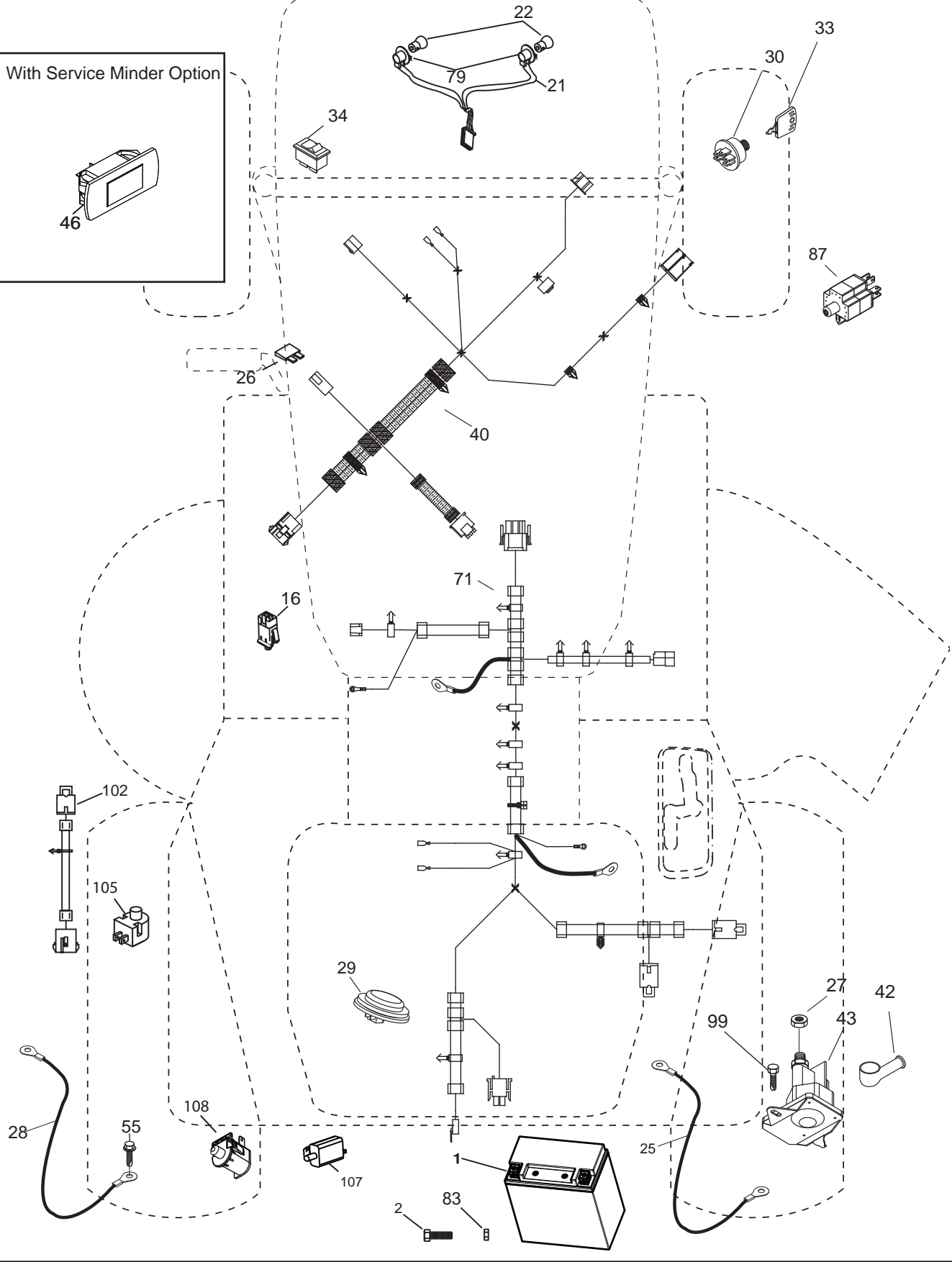
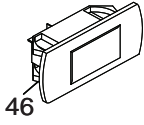

**TRACTOR - MODEL NO. LT2317 CMA (96051002100), PROD. NO. 960 51 00-21
ELECTRICAL 32**

KEY NO.	PART NO.	DESCRIPTION
1	532 43 71-57	Battery
2	532 44 09-23	Screw Hex Head Cap M6 x 1.12 mm
16	532 17 61-38	Switch Interlock Push-In
21	532 40 02-52	Harness Socket Light w/4152J
22	532 00 41-52	Bulb Light
25	532 43 71-62	Cable Starter
26	532 17 51-58	Fuse
27	873 51 04-00	Nut Keps Hex 1/4-20 unc
28	532 43 71-63	Cable, Ground
29	532 40 15-45	Switch, Seat
30	532 19 33-50	Switch, Ign.
33	532 41 19-35	Key/Chain
34	532 11 07-12	Switch Light/Reset
40	532 42 10-02	Harness Ign. Dash
42	532 13 15-63	Cover, Terminal
43	532 19 25-07	Solenoid
55	817 06 05-12	Screw Thdrol. 5/16-18 x 3/4 TYTT
71	532 44 08-19	Harness Chassis
79	532 17 52-42	Socket Asm. Bulb Twistlock
83	532 43 67-74	Nut Square M6 x 1.8.5 x 11 mm
87	532 42 10-60	Switch Interlock Clutch Cable
99	817 72 04-08	Screw 1/4-20 x 1/2
102	532 40 44-54	Harness Pigtail
105	532 40 75-68	Switch Reversing
107	532 18 03-79	Switch Full Bagger Indicator
108	532 42 10-62	Switch Snapmount

NOTE: All component dimensions given in U.S. inches
1 inch = 25.4 mm

TRACTOR - MODEL NO. LT2317 CMA (96051002100), PROD. NO. 960 51 00-21
CHASSIS AND ENCLOSURES 39

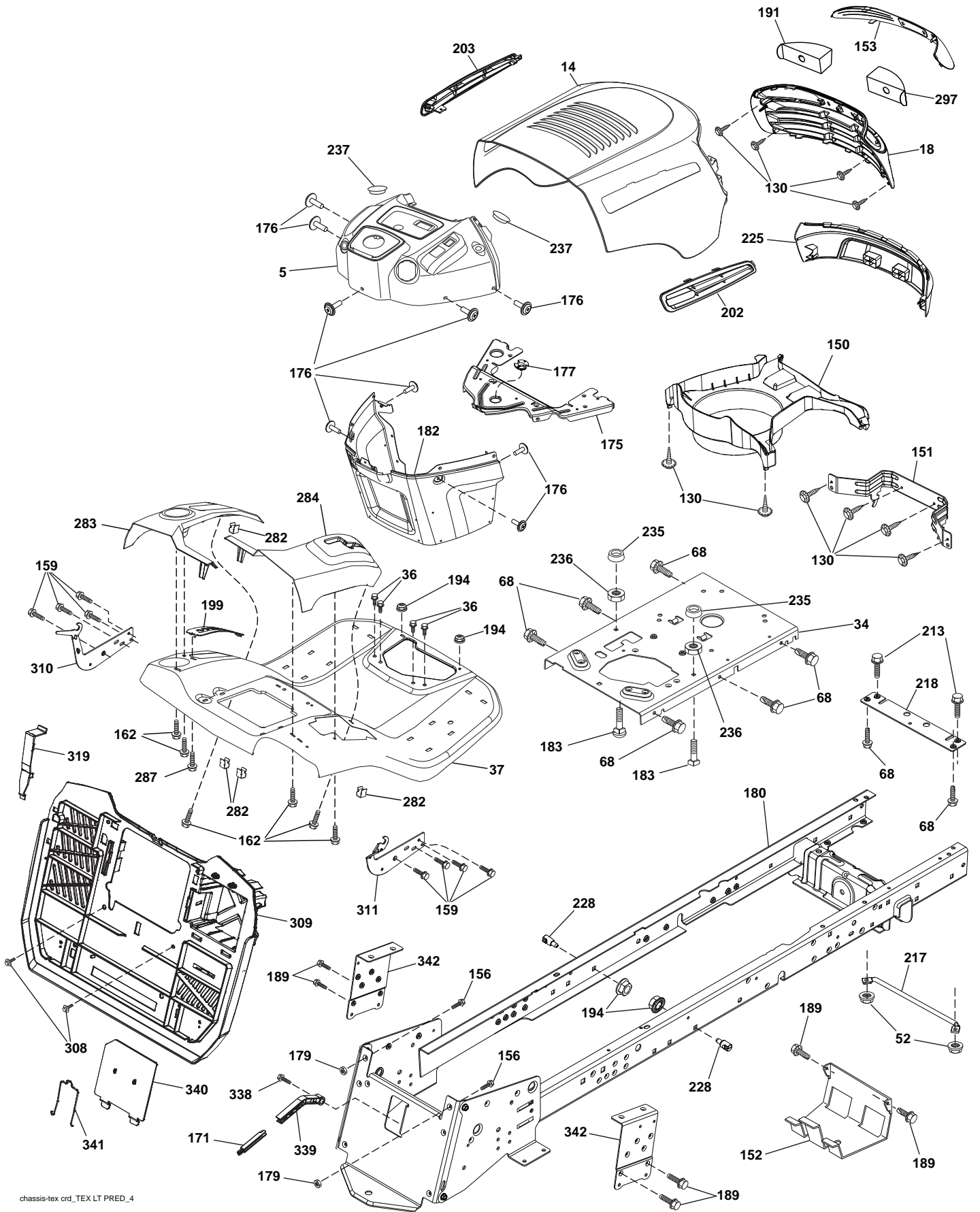

chassis-tex crd_TEX LT PRED_4

**TRACTOR - MODEL NO. LT2317 CMA (96051002100), PROD. NO. 960 51 00-21
CHASSIS AND ENCLOSURES 39**

KEY NO.	PART NO.	DESCRIPTION	KEY NO.	PART NO.	DESCRIPTION
5	532 40 95-97	Dash	213	874 76 05-12	Bolt Hex HD 5/16-18 unc 3/4
14	532 44 12-87	Hood	217	532 40 91-67	Rod Pivot Hood
18	532 42 65-11	Grille	218	532 19 63-95	X-Piece Hood Stop
34	532 19 61-25	Plate Engine	225	532 44 14-87	Bumper Grille
36	817 06 05-12	Screw 5/16-18 x 3/4	228	532 19 51-61	Stud Fastener
37	532 44 22-31	Fender	235	532 40 61-29	Spacer Fender
52	873 68 05-00	Nut Crownlock 5/16-18	236	873 93 05 00	Nut Center Lock 5/16-18 unc
68	817 49 05-08	Screw Thdrol. 5/16-18 x 1/2	237	532 40 37-04	Plug Mount Cargo
130	532 41 63-58	Screw #10 x .750 BOS Thread	282	532 41 41-10	Clip Retainer
150	532 40 02-67	Air Duct	283	532 44 03-61	Console Deck Lift
151	532 18 75-68	Bracket Pivot	284	532 44 12-92	Console Shift RH
152	532 19 95-35	Shield Browning	287	817 60 04-06	Screw Hex Wash. 1/4-20 x 3/8
153	532 40 97-40	Lens	297	532 40 18-27	Insert Reflective LH
156	872 14 06-14	Bolt 3/8-16 unc x 1-3/4	308	532 17 18-77	Bolt 5/16-18 unc x 3/4
159	817 00 06-12	Screw 3/8-16 x 3/4	309	532 43 66-26	Backplate
162	532 14 24-32	Screw Hex Wsh. Hi-Lo 1/4 x 1/2 unc	310	532 43 68-88	Bracket Hangbar Bag LH
171	532 44 12-89	Extension Bagger Full	311	532 43 68-89	Bracket Hangbar Bag RH
175	532 19 94-72	Crossmember	319	532 17 46-62	Bracket Actuator Bagger
176	532 40 07-76	Screw 10-24 x 5/8	338	532 43 66-40	Bolt Shoulder
177	532 19 52-28	Bushing Steering	339	532 43 66-41	Lever Bagger Full
179	532 16 89-37	Nut Push	340	532 44 09-31	Door Battery Tray
180	532 43 54-72	Chassis	341	532 43 66-38	Latch Batter Tray
182	532 40 71-76	Dash Lower	342	532 43 59-38	Support Fender
183	874 52 05-20	Bolt 5/16-18 x 1-1/4	--	532 40 37-04	Plug Mount
189	817 00 05-12	Screw 5/16-18 x 3/4			
191	532 41 65-02	Insert Reflective RH			
194	873 90 05-00	Nut Lock Hex Flange 5/16-18			
199	532 41 87-39	Plate Deck Lift			
202	532 42 33-17	Vent Side Hood RH			
203	532 42 33-16	Vent Side Hood LH			

NOTE: All component dimensions given in U.S. inches
1 inch = 25.4 mm

TRACTOR - MODEL NO. LT2317 CMA (96051002100), PROD. NO. 960 51 00-21
DRIVE **40**

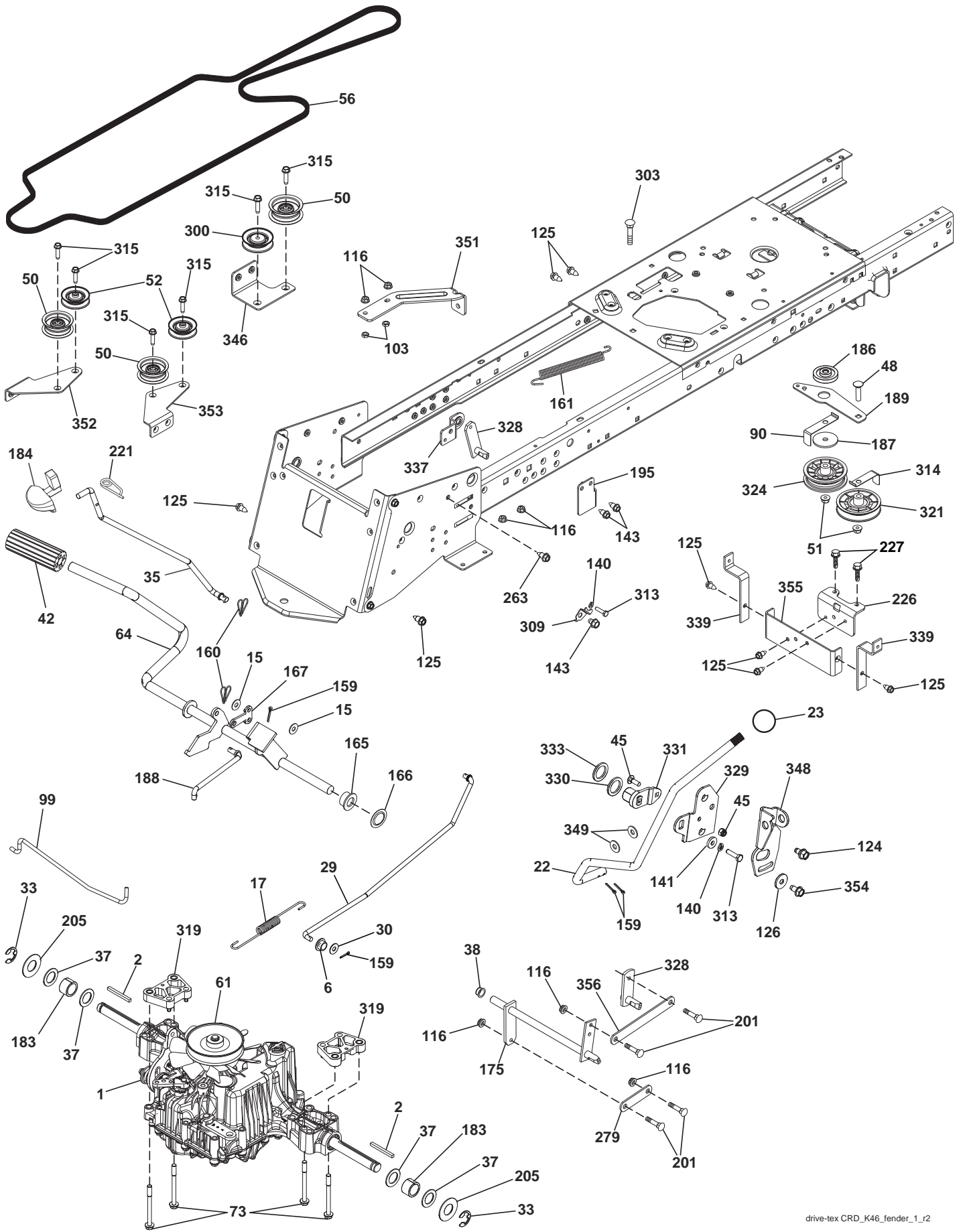

drive-tex CRD_K46_fender_1_r2

**TRACTOR - MODEL NO. LT2317 CMA (96051002100), PROD. NO. 960 51 00-21
DRIVE **40****

KEY NO.	PART NO.	DESCRIPTION	KEY NO.	PART NO.	DESCRIPTION
1	532 43 63-79	Transaxle, Tufftorq K46DC	187	819 13 32-10	Washer
2	532 12 35-83	Key Square	188	532 19 43-23	Link Clutch Ground Drive
6	532 12 42-08	Bushing Snap	189	532 43 36-11	Bellcrank Ground Drive
15	819 13 13-16	Washer 13/32 x 13/16 x 16 Ga.	195	532 43 58-65	Bracket Rod Brake
17	532 43 62-27	Spring, Brake	201	532 16 96-12	Bolt Shoulder 5/16-18 unc
22	532 43 56-70	Rod Shift	205	532 12 17-48	Washer 25/32 x 1-5/8 x 16 Ga.
23	532 13 05-64	Knob	221	532 40 31-87	Retainer Spring
29	532 43 58-81	Rod, Brake	226	532 40 15-64	Bracket Mount Torque
30	819 13 16-16	Washer	227	817 49 05-12	Screw Thdrol 5/16-18 x 3/4
33	812 00 00-01	Ring E	263	817 00 06-12	Screw Thdr 3/8-16 x 3/4
35	532 40 10-31	Rod, Brake, Park	279	532 43 72-62	Link Shift
37	532 12 17-49	Washer 25/32 x 1-1/4 x 16 Ga.	300	532 19 95-34	Pulley V-Idler
38	532 16 96-13	Nyliner Snap In	303	872 11 06-18	Bolt 3/8-16 x 2-1/4
42	532 12 48-72	Cover, Foot Pedal	309	532 16 55-80	Plate Fstnr. Cross
45	873 80 04-00	Lock Nut 1/4-20	313	874 78 04-16	Bolt Hex Fin 1/4-20 unc x 1 Gr. 5
48	872 11 06-12	Bolt Carr. 3/8-16 x 1-1/2 Gr. 5	314	532 12 32-05	Retainer Belt Spring
50	532 43 68-12	Pulley Idler Flat	315	817 58 05-20	Screw Thdrol 5/16-18 x 1.25
51	873 90 06-00	Lock Nut 3/8-16	319	532 43 67-94	Spacer Transaxle
52	532 19 95-34	Idler V Pulley Grnd. Dr.	321	532 12 77-83	Pulley Idler Groove
56	532 17 01-40	V-Belt, Drive	324	532 43 82-85	Pulley Idler Composite
61	532 43 77-88	Pulley Transaxle	328	532 43 57-58	Shaft Shift Front
64	532 19 62-00	Shaft Asm. Pedal Brake Control	329	532 43 74-58	Bracket Shift Mount
73	874 49 05-56	Bolt Hex 5/16-18 x 2-1/2 G5	330	532 16 95-93	Washer Nyliner
90	532 43 98-48	Keeper Belt Clutching	331	532 18 39-00	Hub Shift
99	532 43 72-10	Rod Spring Bypass	337	532 43 59-37	Bracket Support Shift
103	873 35 05-00	Nut Hex Jam 5/16-18 unc	339	532 43 68-67	Strap Torque
116	873 90 05-00	Nut Lock Hex Flange 5/16-18	346	532 43 02-08	Bracket V-Idler
124	532 16 54-92	Bolt Shoulder 5/16-18 x .561	348	532 43 82-50	Bracket Pivot Lever
125	817 00 05-12	Screw 5/16-18 x 3/4	349	819 17 12-16	Washer 17/32 x 3/4 x 16 Ga.
126	532 16 60-02	Washer Srrtd. 5/16 ID x 1 x .125	351	532 43 69-98	Bracket Deck Sway
140	810 04 04-00	Washer Lock 1/4	352	532 43 58-19	Bracket Idler
141	819 09 12-10	Washer 9/32 x 3/4 x 10 Ga.	353	532 43 65-77	Bracket Idler RH
143	817 49 05-08	Screw Thdrol 5/16-18 x 1/2	354	817 49 05-10	Screw 5/16-18 x 5/8
159	876 02 04-12	Pin Cotter 1/8 x 3/4	355	532 43 56-99	Bracket
160	532 16 94-84	Retainer Clip	356	532 43 64-64	Link Shift Cross Shaft
161	532 10 57-09	Spring, Return, Clutch	- - -	532 17 08-68	Washer Spring Wave
165	532 19 62-12	Nyliner			
166	532 42 91-64	Nut Push .625			
167	532 40 52-57	Latch Brake Parking			
175	532 44 18-23	Shaft Asm Shift			
183	532 13 70-57	Spacer Axle			
184	532 40 97-47	Handle Parking Brake			
186	532 19 43-21	Spacer Retainer			

NOTE: All component dimensions given in U.S. inches
1 inch = 25.4 mm

TRACTOR - MODEL NO. LT2317 CMA (96051002100), PROD. NO. 960 51 00-21
ENGINE 24

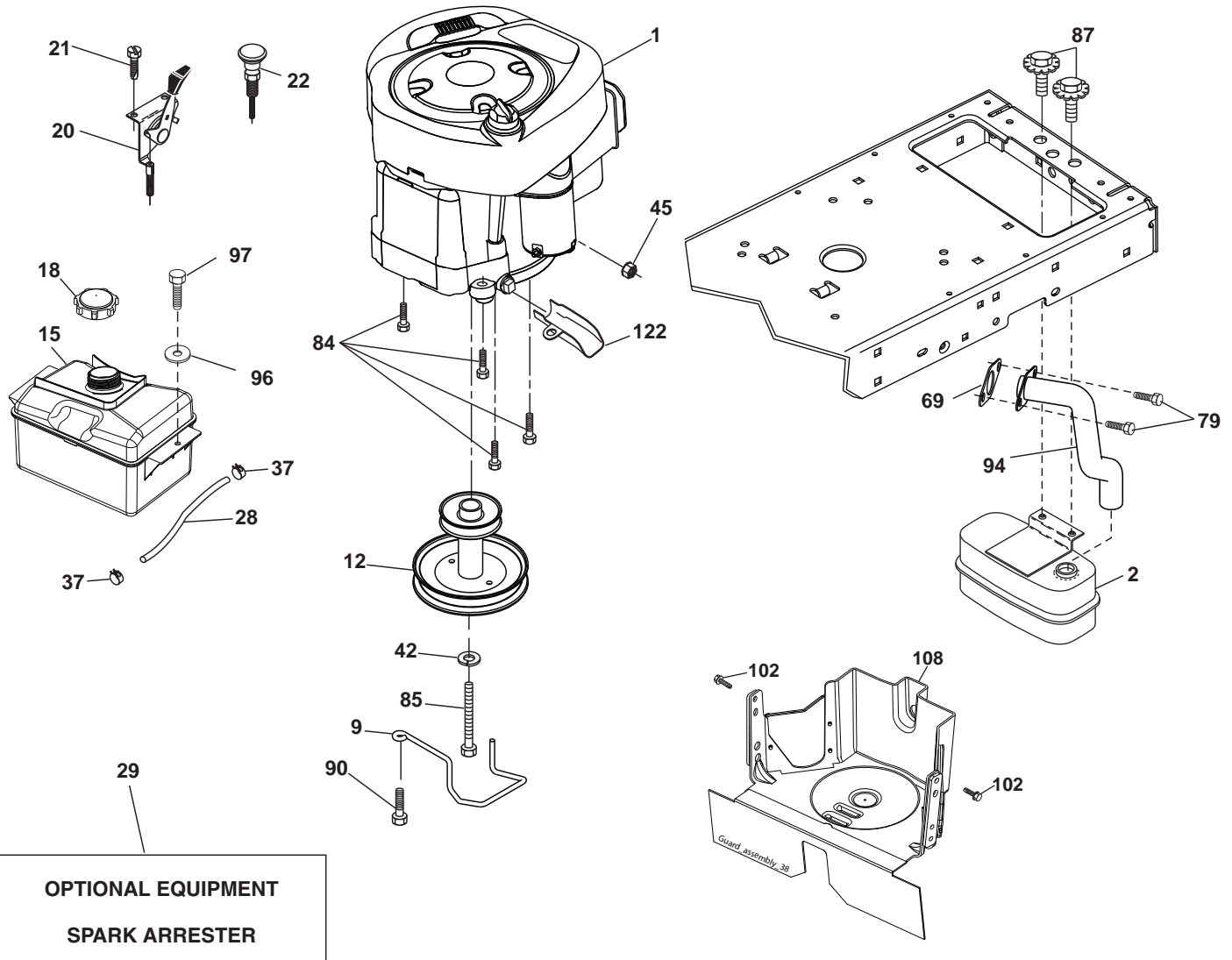

engine-tex-BS_39

**TRACTOR - MODEL NO. LT2317 CMA (96051002100), PROD. NO. 960 51 00-21
ENGINE 24**

KEY NO.	PART NO.	DESCRIPTION
1	532 43 85-86	Engine Briggs Model 31E777-2439-B1
2	532 18 86-55	Muffler
9	532 19 43-20	Keeper Belt Engine
12	532 40 54-71	Pulley Engine
15	532 40 75-45	Tank Fuel 1.5
18	532 43 02-20	Cap Fuel
20	532 18 38-97	Control Throttle
21	532 41 63-58	Screw #10 x 0.750 BOS Thread
22	532 18 38-97	Control Choke
28	532 13 70-40	Fuel Line
29	532 13 71-80	Spark Arrester Kit
37	532 12 34-87	Clamp Hose
42	810 04 07-00	Lock Washer Hvy. 7/16
45	873 51 04-00	Nut Keps Hex 1/4-20 unc
69	532 16 52-91	Gasket
79	532 19 23-34	Screw Socket HD 5/16-18 x .75
84	817 06 06-20	Screw 3/8-16 x 1
85	532 17 39-37	Bolt Hex 7/16-20 x 4 x Gr. 5-1.5 Thr
87	532 17 18-77	Bolt 5/16-18 unc x 3/4 w/Sems.
90	817 00 06-16	Screw 3/8-16 x 1
94	532 40 54-50	Tube Exhaust
96	819 09 14-16	Washer 9/32 x 7/8 x 16 Ga.
97	817 67 04-12	Screw 1/4-20 x 3/4
102	817 06 05-16	Screw 5/16-18 x 1
108	532 42 30-41	Cover Pulley
122	532 42 19-22	Extension Drain Oil

NOTE: All component dimensions given in U.S. inches
1 inch = 25.4 mm

Engine Power Rating Information

The gross power rating for individual gas engine models is labeled in accordance with SAE (Society of Automotive Engineers) code J1940 (Small Engine Power & Torque Rating Procedure), and rating performance has been obtained and corrected in accordance with SAE J1995 (Revision 2002-05). Torque values are derived at 3060 RPM; horsepower values are derived at 3600 RPM. Actual gross engine power will be lower and is affected by, among other things, ambient operating conditions and engine-to-engine variability. Given both the wide array of products on which engines are placed and the variety of environmental issues applicable to operating the equipment, the gas engine will not develop the rated gross power when used in a given piece of power equipment (actual "on-site" or net power). This difference is due to a variety of factors including, but not limited to, accessories (air cleaner, exhaust, charging, cooling, carburetor, fuel pump, etc.), application limitations, ambient operating conditions (temperature, humidity, altitude), and engine-to-engine variability. Due to manufacturing and capacity limitations, Briggs & Stratton may substitute an engine of higher rated power for this Series engine.

TRACTOR - MODEL NO. LT2317 CMA (96051002100), PROD. NO. 960 51 00-21
STEERING ASSEMBLY 41

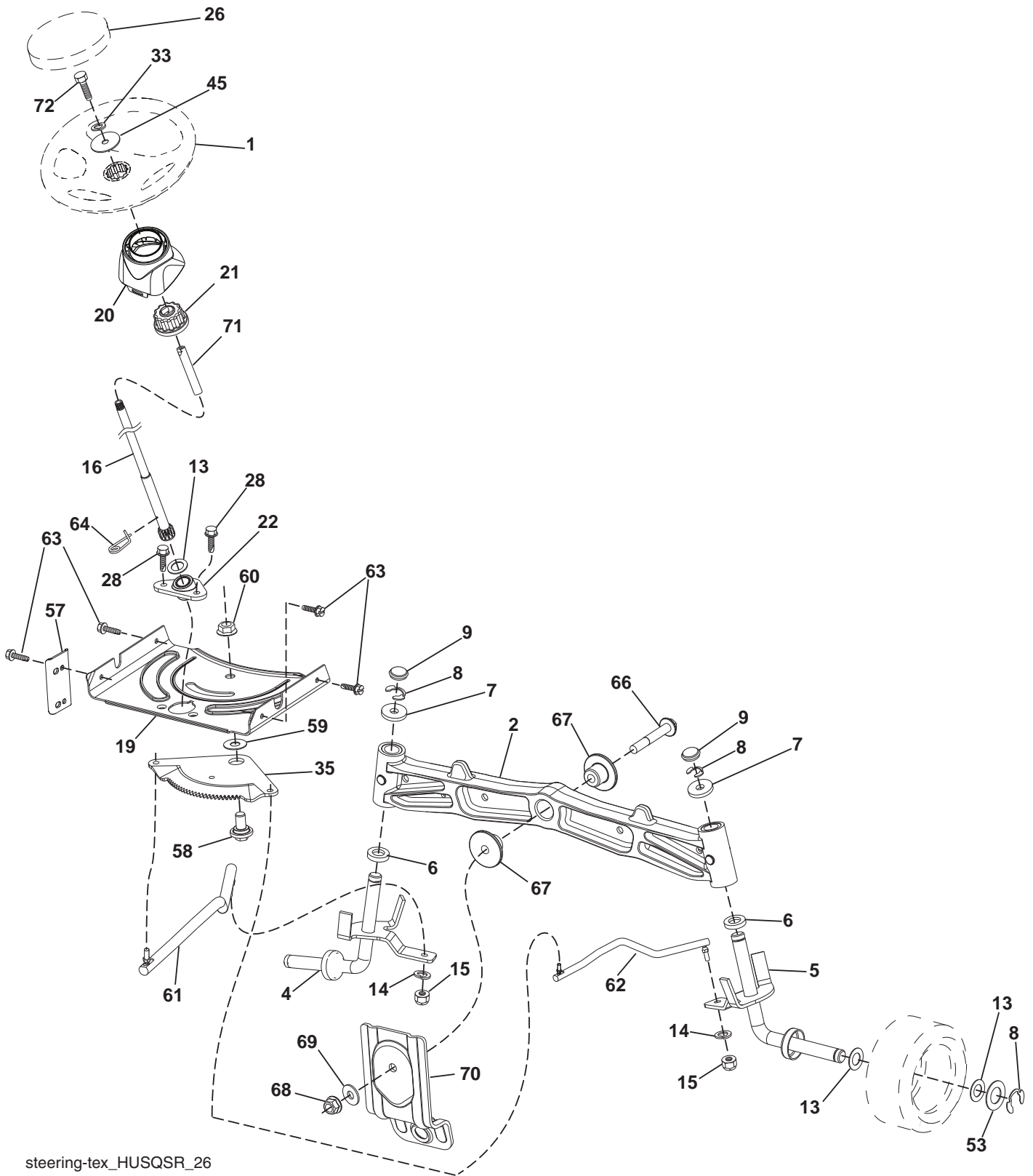

steering-tex_HUSQSR_26

**TRACTOR - MODEL NO. LT2317 CMA (96051002100), PROD. NO. 960 51 00-21
STEERING ASSEMBLY **41****

KEY NO.	PART NO.	DESCRIPTION
1	532 19 46-37	Wheel, Steering Husq SR
2	532 19 59-68	Axle Asm., Front
4	532 40 30-87	Spindle Asm., LH
5	532 40 30-88	Spindle Asm., RH
6	532 12 49-31	Bearing, Race Thrust Hardened
7	532 12 17-48	Washer 25/32 x 1-5/8 x 16 Ga.
8	812 00 00-29	Ring, Clip #T5304-75
9	532 12 12-32	Cap, Spindle
13	532 12 17-49	Washer 25/32 x 1-1/4 x 16 Ga.
14	810 04 06-00	Washer, Lock Hvy. Hlcl. Spr. 3/8
15	873 54 06-00	Nut, Crown Lock 3/8-24 unf
16	532 42 93-73	Shaft Steering
19	532 19 47-29	Plate Steering
20	532 42 47-02	Boot, Steering
21	532 18 67-37	Adapter, Wheel Steering
22	532 42 05-37	Supt., Strg. Lower
26	532 19 46-03	Insert, Wheel Steering Husq SR
28	817 00 06-12	Screw 3/8-16 x 3/4
33	810 04 05-00	Washer Lock 5/16
35	532 19 47-32	Gear, Sector Plate
45	819 11 38-12	Washer 11/32 x 3/8 x 12 Ga.
53	532 18 89-67	Washer Hardened .793 x 1.637 x .060
57	532 40 74-65	Bracket Upstop
58	532 19 47-47	Bolt Shoulder Sector Pivot CFM
59	532 19 47-48	Washer Thrust Sector Steering
60	873 97 10-00	Nut Flange Lock 5/8-11
61	532 19 47-40	Draglink, LH
62	532 19 47-41	Draglink, RH
63	817 00 05-12	Screw 5/16-18 x 3/4
64	532 19 98-49	Retainer Clip Spring Steering
66	871 02 07-48	Bolt Hex Fghd. 7/16-14 x 3 Serr.
67	532 19 47-37	Bushing PM Front Axle
68	873 90 07-00	Nut Lock Flange 7/16-14 Gr. 5
69	532 19 91-62	Washer 1.5 x .505 x .118
70	532 19 61-97	Bracket Deck Susp. Front
71	532 19 07-52	Shaft Extension Steering
72	532 42 89-82	Bolt Fin Hx 5/16-18 x 4 w/Patch

NOTE: All component dimensions given in U.S. inches
1 inch = 25.4 mm

TRACTOR - MODEL NO. LT2317 CMA (96051002100), PROD. NO. 960 51 00-21
 MOWER DECK **44**

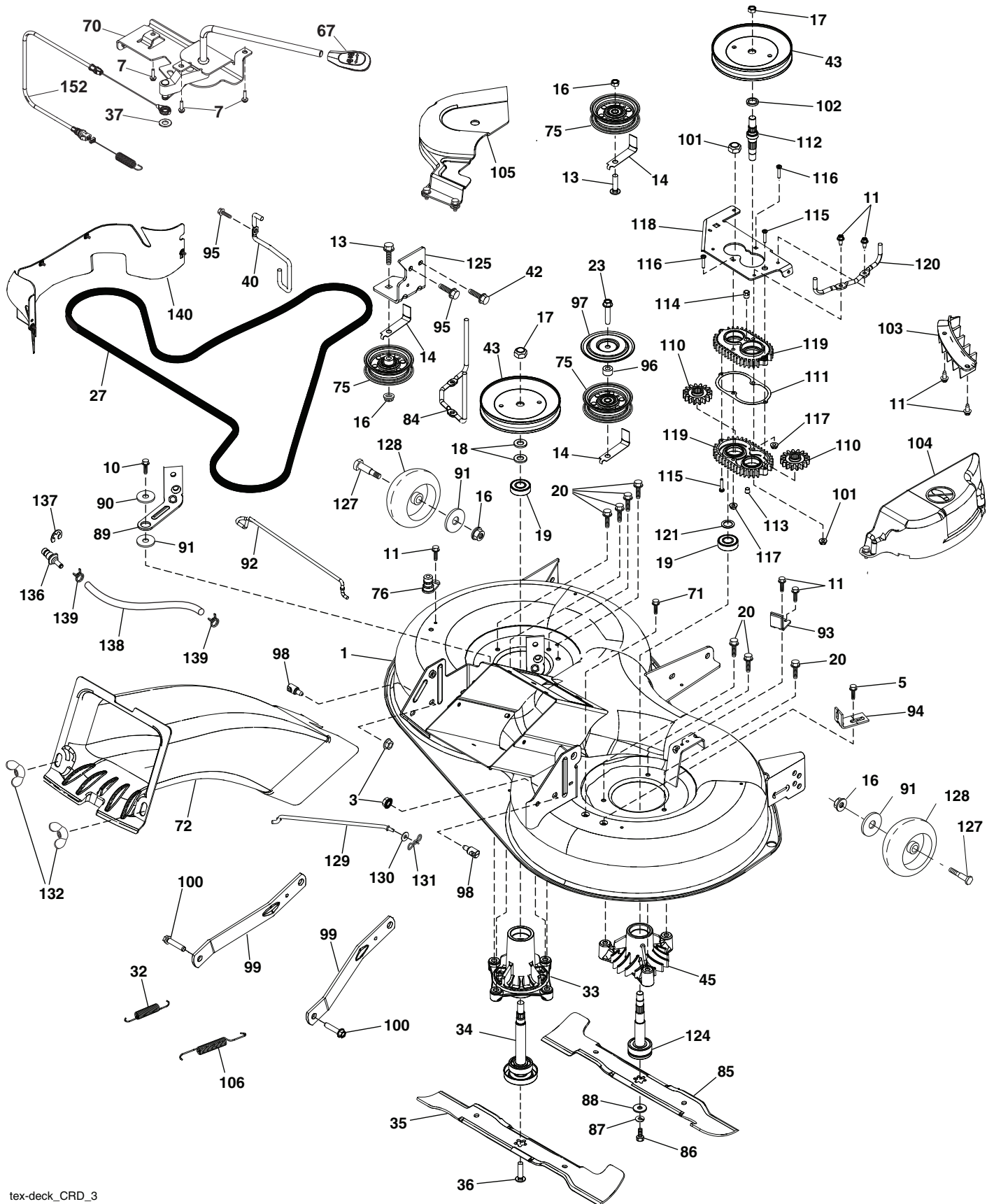

tex-deck_CRD_3

**TRACTOR - MODEL NO. LT2317 CMA (96051002100), PROD. NO. 960 51 00-21
MOWER DECK 44**

KEY NO.	PART NO.	DESCRIPTION	KEY NO.	PART NO.	DESCRIPTION
1	532 43 69-70	Deck Weldment	98	532 19 51-61	Stud Fastener
3	873 90 05-00	Nut Lock Hex Flange 5/16 - 18	99	532 19 51-86	Arm Suspension Mower Rear
5	817 00 05-10	Bolt 5/16-18	100	532 19 65-39	Bolt Shoulder
7	532 41 63-58	Screw #10 x 0.750 BOS Thread	101	873 68 09-00	Nut Crownlock 9/16 - 18 unc
11	532 13 77-29	Screw Thd Roll 1/4 - 20 X 5/8	102	532 40 25-11	Spacer Bearing Swing Plate
13	872 11 06-12	Bolt Carr Sh 3/8 - 16 X 1 - 1/2 Gr. 5	103	532 43 69-92	Guard Front Vent
14	532 15 60-85	Keeper Belt Idler	104	532 43 89-68	Mandrel Cover RH
16	873 90 06-00	Nut Lock FIG 3/8 - 16 unc	105	532 43 87-44	Mandrel Cover LH
17	532 40 02-34	Nut Flange Lock Top	106	532 19 32-16	Spring Brake Return
18	532 18 76-90	Washer Spacer Mandrel	110	532 41 53-56	Gear Output
19	532 11 04-85	Bearing Ball Mandrel	111	532 43 69-79	Gasket Gearcase
20	532 17 39-84	Screw Thread Roll	112	532 43 69-88	Shaft Gearcase
23	817 49 06-28	Screw Thdrol 3/8 - 16 X 1-3/4	113	532 43 85-33	Plug Oil
10	817 00 06-16	Screw 3/8-16x1 smgml tap	114	532 43 85-34	Valve Relief
27	532 43 97-26	V-Belt Drive	115	818 03 10-16	Screw Torx #10-24 x 1
32	532 40 18-72	Spring Return Deck	116	872 11 04-14	Bolt 1/4-20 x 1.75 Gr. 5
33	532 18 72-81	Housing Mandrel 4pt Service	117	873 90 04-00	Nut Hex Flange 1/4-20 unc
34	532 19 28-72	Shaft Asm Mndrl N/Greaseable38	118	532 43 69-89	Arm Clutching
35	532 42 79-84	Blade Mower LH	119	532 43 81-66	Gearcase Subasm
36	532 19 30-03	Bolt/Washer Asm 7/16 - 20 unf	120	532 43 69-91	Keeper Belt RH
37	819 13 13-16	Washer 13/32 x 13/16 x 16 Ga.	121	532 43 69-85	Washer
40	532 19 72-58	Keeper Belt Engine LH	124	532 43 69-86	Non Greasable Mandrel Shaft
42	817 00 05-12	Screw 5/16-18 x 3/4	125	532 43 69-94	Bracket Idler Chasses
43	532 19 74-73	Pulley Mandrel	127	532 19 34-06	Bolt Shoulder 3/8-16 x 3-5/8 Gr. 5
45	532 13 71-52	Housing Mandrel	128	532 17 48-73	Wheel Guage
67	532 40 30-12	Handle Clutch Cable	129	532 40 48-51	Rod Anti-Sway
70	532 40 12-46	Clutch Asm Manual LT Pred	130	819 13 13-12	Washer 13/32 x 13/16 x 12 Ga.
71	817 67 06-08	Screw Thdrol 3/8-16 x 1/2	131	532 19 42-08	Pin Cotter 5/16 Bow Tie Lock
72	532 43 66-58	Chute Upper	132	532 17 88-99	Knob Handle
75	532 13 14-94	Pulley Idler Flat	136	532 43 96-39	Washout Port Hookup
76	532 43 96-40	Washout Port	137	812 00 00-29	Ring Klip
80	532 42 30-62	Palnut 1/4"	138	532 44 07-43	Hose 3/8 Long 12"
84	532 43 25-20	Keeper Belt LH Mandrel	139	532 44 07-42	Hose 3/8 Clamp
85	532 42 79-85	Blade Mower RH	140	532 43 94-73	Guard Asm LH
86	532 18 17-13	Bolt 3/8-24 x 1.50 Gr. 8	152	532 44 04-88	Cable Clutch Manual w/Spring
87	810 03 06-00	Washer Lock Hvy 3/8	--	532 19 28-70	Mandrel Assembly (Includes Housing, Shaft Assembly, And Bearing Only - Pulley/Nut/Washer And Blade Bolt/Washers Not Included)
88	532 14 02-96	Washer Hard Blade Mower Vented	--	532 44 14-23	Replacement Mower Complete
89	532 43 81-24	Arm Brake 97 LH			
90	532 19 90-92	Spacer Retainer			
91	819 13 20-12	Washer 13/32 x 1-1/4 x 12 Ga.			
92	532 43 69-93	Rod Brake			
93	532 43 81-25	Arm Brake RH			
94	532 19 72-50	Bracket Clutch Cable			
95	817 00 06-12	Screw 3/8-16 x 3/4			
96	532 40 02-71	Spacer			
97	532 18 20-61	Shield Idler Mower			

NOTE: All component dimensions given in U.S. inches
1 inch = 25.4 mm

TRACTOR - MODEL NO. LT2317 CMA (96051002100), PROD. NO. 960 51 00-21
MOWER LIFT 45

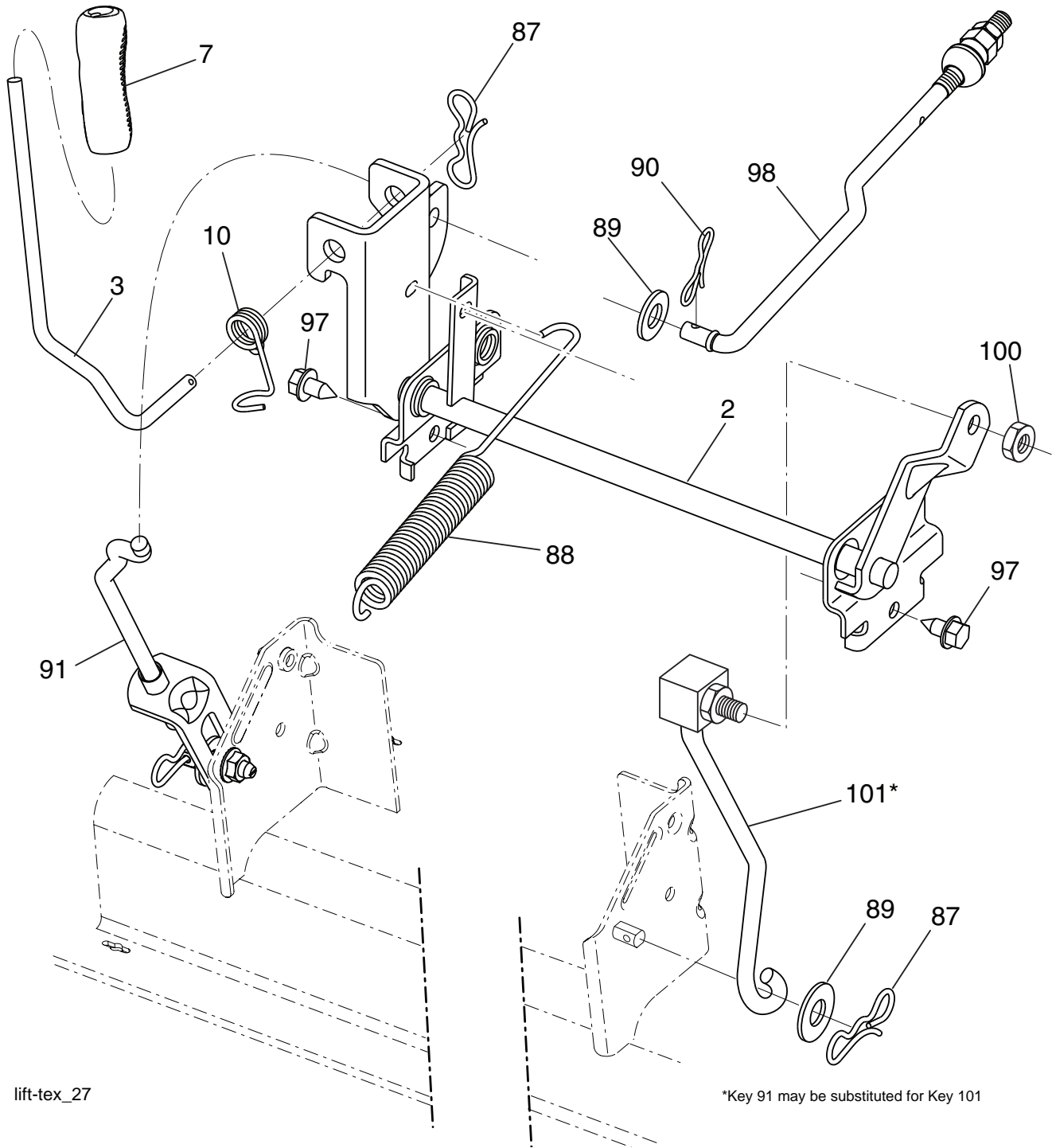

lift-tex_27

*Key 91 may be substituted for Key 101

KEY NO.	PART NO.	DESCRIPTION
2	532 43 69-96	Deck Lift Weldment
3	532 19 52-31	Lever Asm., Lift RH
7	532 41 15-55	Grip, Lever
10	532 19 63-14	Spring Torsion
87	532 19 42-09	Pin Cotter 7/16 Bow Tie Lock
88	532 43 69-95	Spring Lift Assist
89	819 19 19-12	Washer Clear Zinc
90	532 19 42-08	Pin Cotter 5/16 Bow Tie Lock

KEY NO.	PART NO.	DESCRIPTION
91	532 19 51-81	Link Lift Susp. Mower Rear
97	817 49 06-08	Screw 3/8-16 x 1/2
98	532 19 52-70	Link Lift Susp. Front Mower
100	873 93 06-00	Nut Centerlock 3/8-16
101	532 40-70-03	Link Asm. Lift FXD

NOTE: All component dimensions given in U.S. inches
 1 inch = 25.4 mm

**TRACTOR - MODEL NO. LT2317 CMA (96051002100), PROD. NO. 960 51 00-21
SEAT ASSEMBLY 42**

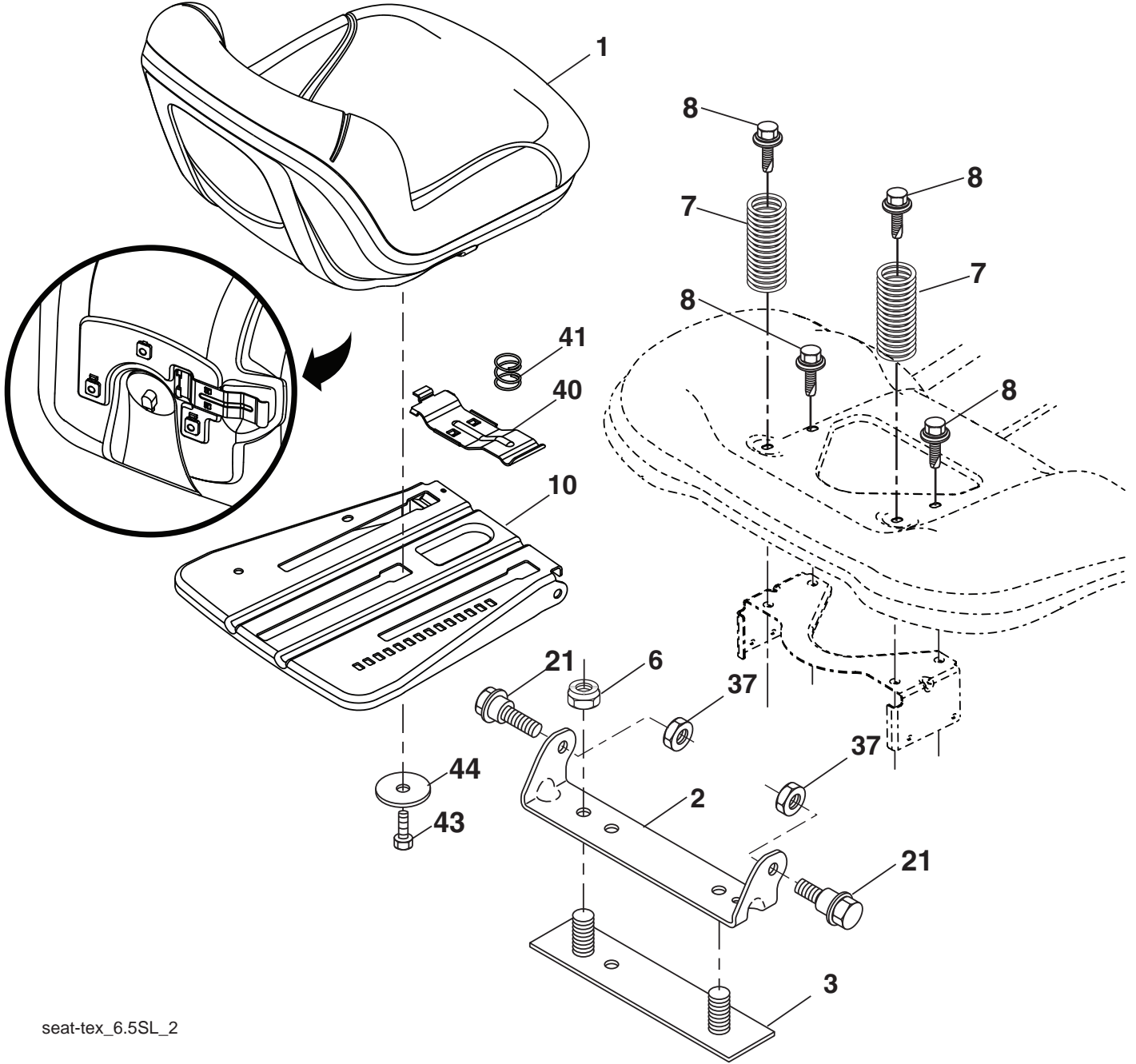

seat-tex_6.5SL_2

KEY NO.	PART NO.	DESCRIPTION
1	532 41 14-05	Seat
2	532 18 01-66	Bracket Pivot Fender
3	532 14 06-75	Strap, Asm. Fender
6	873 80 06-00	Nut, Lock w/Ins. 3/8-16 unc
7	532 12 41-81	Spring, Seat Cprsn.
8	532 17 18-77	Bolt 5/16-18 unc x 3/4 w/Sems.
10	532 19 69-77	Pan, Seat
21	532 17 18-52	Bolt, Shoulder 5/16-18

KEY NO.	PART NO.	DESCRIPTION
37	873 80 05-00	Nut, Lock 5/16-18 unc
40	532 19 76-61	Handle
41	532 19 82-00	Spring
43	874 76 06-12	Bolt 3/8-16 unc x 3/4
44	819 13 38-12	Washer 13/32 x 2-3/8 x 12 Ga.

NOTE: All component dimensions given in U.S. inches
1 inch = 25.4 mm

TRACTOR - MODEL NO. LT2317 CMA (96051002100), PROD. NO. 960 51 00-21
BAGGER 46

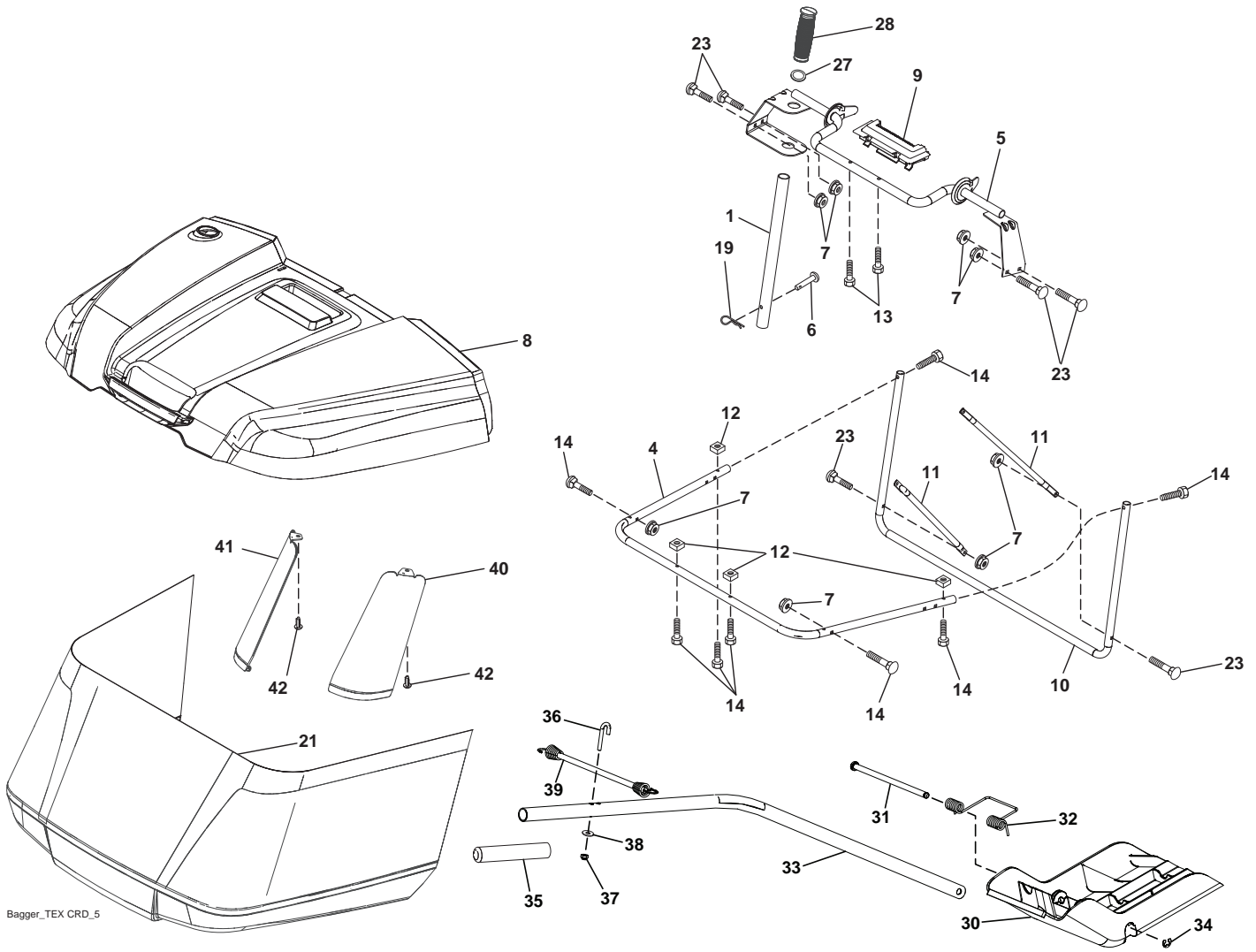

Bagger_TEX CRD_5

KEY NO.	PART NO.	DESCRIPTION
1	532 42 86-10	Tube Handle Bagger
4	532 43 96-12	Frame Asm Bagger Top
5	532 41 76-32	Frame Asm Top Bagger
6	532 12 68-75	Rivet Drilled
7	873 90 04-00	Nut Hex Flange 1/4-20 unc
8	532 44 12-61	Cover Bagger
9	532 41 76-29	Insert Handle Bagger
10	532 43 67-70	Frame Front
11	532 43 67-71	Tubing Brace Bagger
12	532 42 17-93	Nut Square 1/4
13	532 42 17-80	Screw 1/4 x 1.150
14	532 42 18-00	Bolt Shoulder 1/2 x 1.150
19	532 19 42-08	Cotter Pin 5/16 Bow Tie
21	532 43 81-62	Bag Asm
23	872 04 04-10	Bolt Carr. 1/4-20
27	532 42 12-62	Grommet Rubber
28	532 16 57-87	Grip Handle Black

KEY NO.	PART NO.	DESCRIPTION
30	532 43 74-52	Plug
31	532 43 58-61	Pin Hinge
32	532 43 74-54	Spring Double Torsion
33	532 43 84-51	Shaft Mulch Plug
34	532 43 79-88	E-Ring 5/16
35	532 43 91-39	Grip Mulch Plug
36	532 43 90-98	Bolt J
37	532 06 91-80	Nut Lock #10-24 unc
38	819 07 08-18	Washer 7/32 x 1/2
39	532 43 92-42	Bungee
40	532 43 94-18	Support Bagger Corner RH
41	532 43 94-35	Support Bagger Corner LH
42	532 44 04-28	Christmas Tree Clip

NOTE: All component dimensions given in U.S. inches
 1 inch = 25.4 mm

